

Descriptions

A **Electric Servo Cylinder**, also known as an electric actuator or servo cylinder, is a linear actuator that utilizes a servo motor to achieve precise and controllable linear motion. Unlike traditional pneumatic or hydraulic cylinders, which rely on compressed air or pressurized fluids, electric servo cylinders employ electrical power to generate force and speed. Push load capacities include **0.5kN, 1.5kN, 2.7kN, 5kN, 6.8kN, 8kN, 20kN, 30kN, 50kN, 100kN, 130kN, 180kN, 200kN, 400kN and 600kN.**

How they work:

- **Motor and Screw Mechanism:** A electric servo cylinder consists of a servo motor, a ball screw, and a piston rod. The servo motor's rotation is converted into linear motion by the ball screw, which drives the piston rod forward or backward.
- **Control System:** A controller manages the entire process. It sends signals to the servo motor to control its speed, position, and torque, thus controlling the precise movement of the cylinder.
- **Feedback Mechanism:** A position feedback mechanism, often an encoder or resolver, monitors the motor's position and provides this information to the controller. The controller then adjusts the motor's operation as needed to maintain accuracy and correct any deviations from the desired position.

Key Features and Advantages:

- **Precision and Control:** electric servo cylinders offer exceptional control over position, speed, and force, allowing for highly accurate and repeatable linear movements.
- **Flexibility:** They can be easily configured and adjusted to meet specific application requirements, including speed and force variations.
- **Energy Efficiency:** electric servo cylinders consume power only when they are actively moving or holding a position, which can lead to energy savings compared to hydraulic systems that require continuous pressure.
- **Quiet Operation:** Unlike pneumatic cylinders which can be noisy due to compressed air release, electric servo cylinders operate almost silently.
- **Clean and Environmentally Friendly:** They do not use hydraulic fluid, eliminating the risk of leaks and environmental contamination.
- **Compact Design:** Integrated electric servo cylinders, where the motor and screw are in a single housing, can offer a smaller footprint compared to traditional actuator/motor combinations.

Applications:

Electric servo cylinders are utilized in a variety of industries and applications requiring precise linear motion control, including:

- **Industrial automation:** positioning and moving workpieces in manufacturing lines and automated systems
- **Robotics:** controlling the movement of robotic arms, grippers, and other components.
- **Medical technology:** adjusting patient beds, operating tables, and diagnostic equipment.
- **Packaging technology:** precise product placement and handling.
- **Material handling:** moving and positioning objects in warehouses and other environments.
- **CNC machines:** providing accurate control for machining operations.

Internal Structure

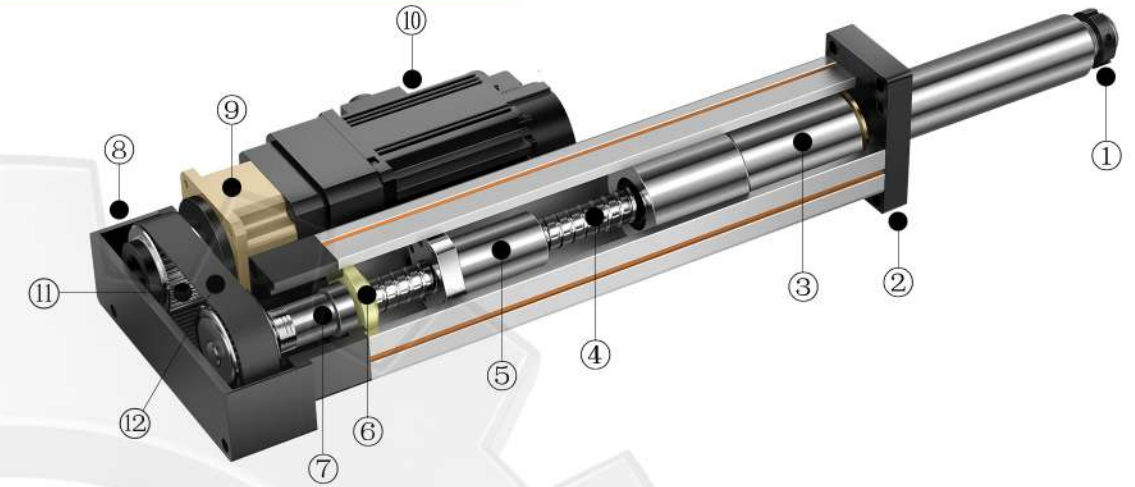

- ①Nut of Piston Rod ②Front Flange ③Piston Rod ④Ball Screw ⑤Ball Nut ⑥Cushion
⑦Bearing Block ⑧Housing ⑨Reducer ⑩Motor ⑪Synchronous Wheel ⑫Timing Belt

Materials



Sample Part Number

Sample Part Number (Example):

KMZ80L05C300P02RER1FCP

(1) Model:

KMZ40	KMZ50	KMZ60	KMZ60Z	KMZ75	KMZ75Z	KMZ80	KMZ94
KMZ94Z	KMZ115	KMZ135	KMZ140	KMZ160	KMZ180	KMZ245	KMZ300

• **Note:** The Push Load, Stroke and Speed of the Servo Electric Cylinders need to be combined with the actual use, and the three upper limits cannot be used in combination at the same time.

Model	Push Load	Stroke (mm)	Cylinder I.D. (mm)	Cylinder O.D. (mm)	Screw Diam. (mm)	Pushrod Diam. (mm)	Direct Motor		Planetary Gear Reducer
							Servo Motor Frame	Stepper Motor Frame	
KMZ40	≤50 kg	≤300	Φ30	40x40	Φ12	Φ20	40	42	—
KMZ50	≤150 kg	≤360	Φ40	53x53	Φ12	Φ25	40, 60	57	—
KMZ60	≤270 kg	≤480	Φ50	61x61	Φ16	Φ35	60	57	—
KMZ60Z	≤500 kg	≤480	Φ50	61x61	Φ16	Φ35	80	86	60
KMZ75	≤680 kg	≤600	Φ63	75x75	Φ20	Φ45	60, 80	86	—
KMZ75Z	≤800 kg	≤600	Φ63	75x75	Φ20	Φ45	100, 130	—	60, 90
KMZ80	≤2 ton	≤750	Φ65	80x80	Φ25	Φ50	80, 100, 130	—	60, 90, 115
KMZ94	≤3 ton	≤960	Φ80	94x94	Φ32	Φ60	80, 100, 130	—	—
KMZ94Z	≤3 ton	≤960	Φ80	94x94	Φ32	Φ60	180	—	85, 90, 115
KMZ115	≤5 ton	≤1200	Φ100	112x112	Φ40	Φ75	130, 180	—	115, 142
KMZ135	≤10 ton	≤1500	Φ120	134x134	Φ50	Φ90	130, 180	—	115, 142
KMZ140	≤13 ton	≤1500	Φ110	Φ132	Φ50	Φ90	—	—	142
KMZ160	≤18 ton	≤1800	Φ140	158x158	Φ63	Φ100	—	—	142, 180
KMZ180	≤20 ton	≤1800	Φ160	180x180	Φ63	Φ120	—	—	142, 180
KMZ245	≤40 ton	≤2400	Φ180	Φ210	Φ80	Φ140	—	—	180, 220
KMZ300	≤60 ton	≤3000	Φ230	Φ280	Φ100	Φ180	—	—	220

* The Gear Reducer Corresponds to the Input Servo Motor Flange

Planetary Gear Reducer Frame	Servo Motor Frame
60	60, 80
85	60, 80, 130
90	60, 80, 100, 130
115	80, 100, 130, 180
142	130, 180
180	180, 200, 220
220	180, 200, 220

Sample Part Number

(2) Ball Screw Lead:

- L05: 5mm • L10: 10mm • L20: 20mm • L25: 25mm • Customize

(3) Stroke:

- C100: 100mm • C300: 300mm • Customize

* There are no “standard” travel lengths, all electric cylinders’ stroke are produced according to your requirements.

(4) Mounting:

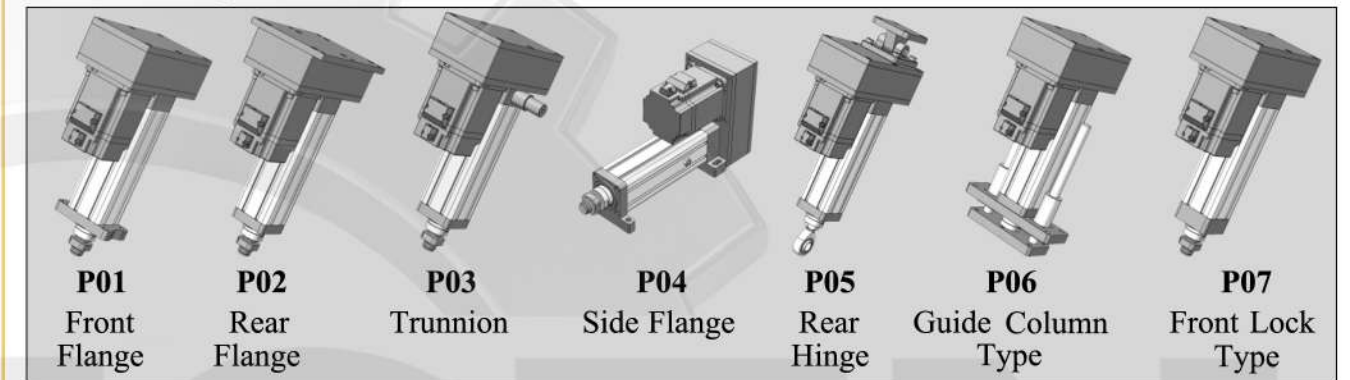

(5) Front Attachment:

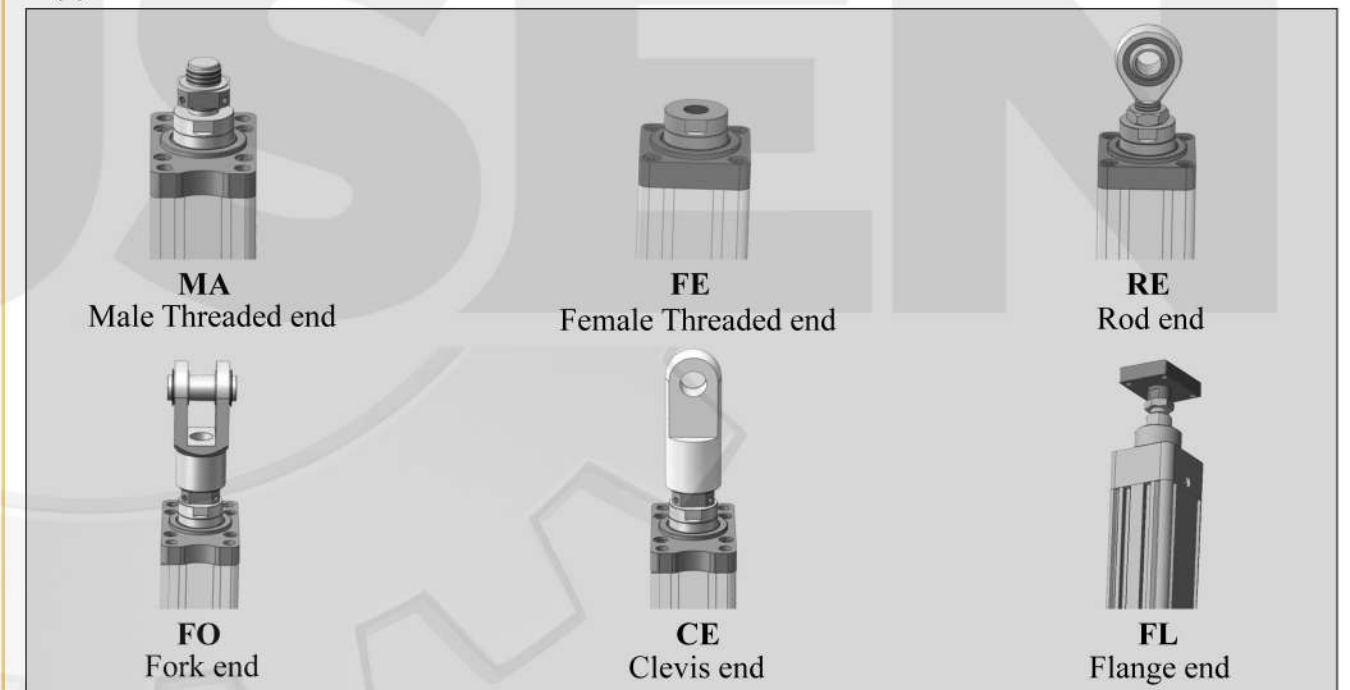

(6) Ratio:

- R1 = 1:1 • R1.5 = 1.5:1 • R2 = 2:1 • R3 = 3:1 • Customize

(7) Accessories:

- AR: Anti-Rotate device • FCM: Magnetic reed switches • FCP: Inductive proximity switches
- SP: Rear bracket • BB: Bellows Boots • PL: Load Sensor

Specifications and Dimensions

KMZ40 Parameters for Standard Configurations

1) Basic Parameters

- (Note: The Push Load, Stroke and Speed of the Servo Electric Cylinders need to be combined with the actual use, and the three upper limits cannot be used in combination at the same time.) all size, easy installation and use, simple maintenance, low noise, long life, multiple safety protection measures.

Cylinder O.D. (mm)	Cylinder I.D. (mm)	Maximum Push Load	Stroke	Maximum Speed	Rotation Degree of Piston Rod	Limit Switches
40x40 mm	Φ30 mm	≤0.5KN	≤300 mm	≤250 mm/s	±0.3°	Magnetic Switches

2) Optional

Screw Lead	Ratio	Direct Motor		Planetary Gear Reducer
		Servo Motor Frame	Stepper Motor Frame	
4mm	1: 1.5: 2:	40	42	N/A
5mm	1 1 1			

3) Screw Parameters

- (Note: The load of the screw is based on Stroke ≤300mm, and the Stroke >300mm needs to consult our technicians.)

Screw Model	Screw Type	Screw Diam.	Screw Lead	Dynamic Load Ca (kN)	Static Load Coa (kN)	Stiffness Kgf/μm
BSH1204-3.5	Ball Screw	12mm	4mm	7.8	16.1	23
BSH1205-3.5			5mm	7.8	16.1	

Screw Model	Ball Diam.	Screw Shaft	Slenderness Ratio	Accuracy Grade / Positioning Accuracy
BSH1204-3.5	2.5mm	8K3	1:30	C5/±0.01
BSH1205-3.5				

4) Bearing Parameters

Bearing Model	Dynamic Load Cr (kN)	Static Load Cor (kN)
Deep Groove Ball Bearing 6900-2RSx2	2.7	1.27

Specifications and Dimensions

5) Synchronous Wheel and Timing Belt Parameters

Ratio	Synchronous Wheels				Timing Belt		
	Drive Wheels		Driven Wheels		Center Distance	Circumference	Width
	Model	Number of Teeth	Model	Number of Teeth			
1:1		30		30	47.5mm	186	10mm
1.5:1	3M10T21	20	3M10T15	30		171	
2:1		20		40		186	

6) Front Attachment Dimensions

Front Attachment	ΦA	ΦB	ΦC	C	D	E	F	H	G	M
Male Threaded end	Φ34	Φ20	—	20	43	3	8	—	17	M12x1.0
Female Threaded end	Φ34	Φ20	—	16	15	3	—	—	17	M10
Clevis end	Φ34	Φ20	Φ10	—	65	3	10	15	17	—
Rod end	Φ34	Φ20	Φ10	—	45	3	14	—	17	—
Fork end	Φ34	Φ20	Φ10	—	65	3	10	40	19	—

Specifications and Dimensions

KMZ40

• Note: When different motors are matched, the dimensions may change.

(P01) Front Flange: L1 = Stroke + 85mm, L2 = Stroke + 149mm

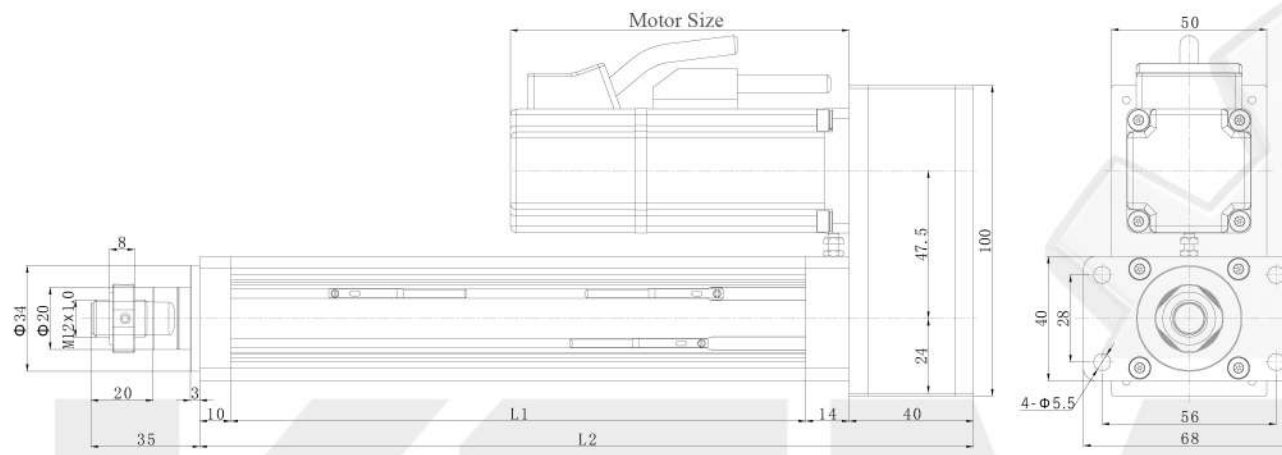

(P02) Rear Flange: L1 = Stroke + 85mm, L2 = Stroke + 139mm

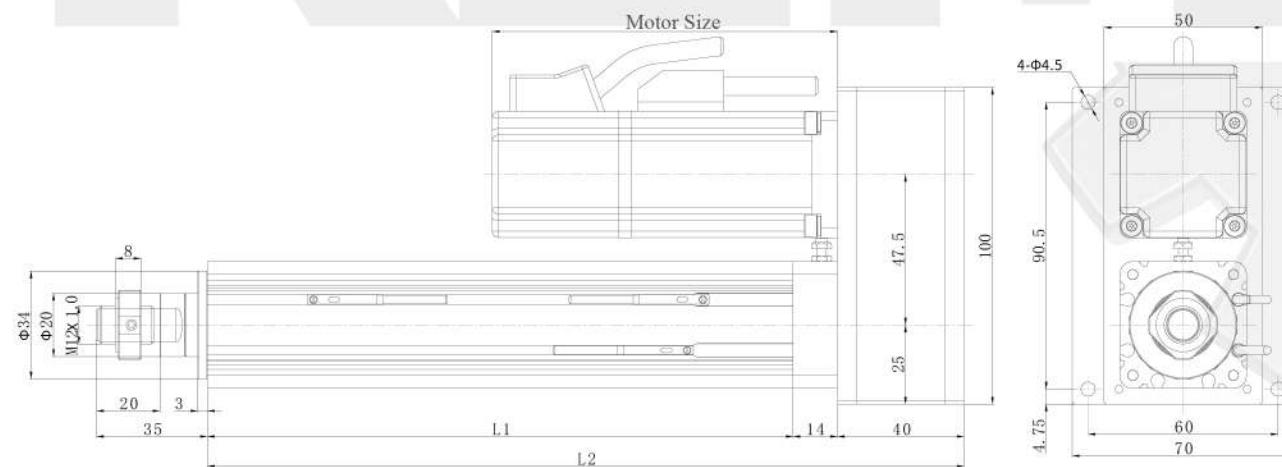

*. Dimensions are subject to change without notice



Specifications and Dimensions

KMZ40

• Note: When different motors are matched, the dimensions may change.

(P03) Trunnion: L1 = Stroke + 85mm, L2 = Stroke + 139mm

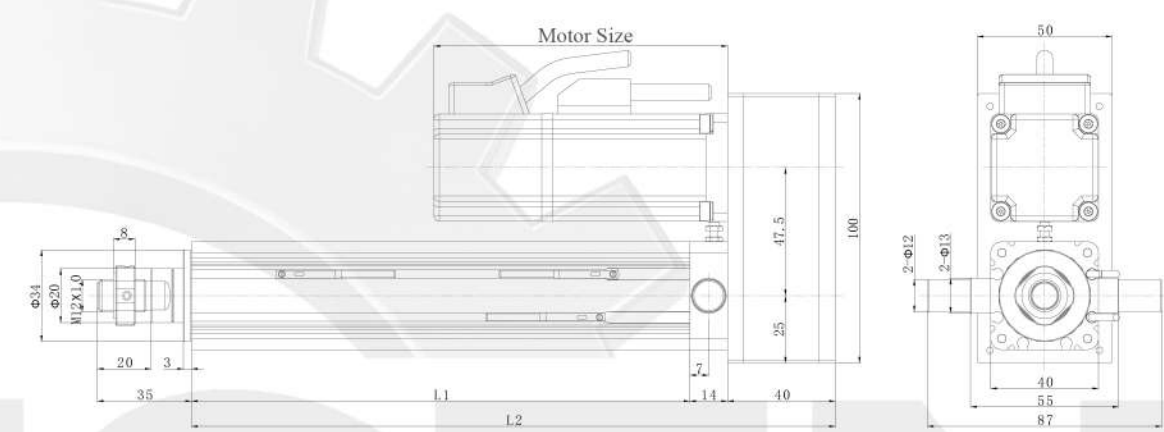

(P04) Side Flange: L1 = Stroke + 85mm, L2 = Stroke + 149mm

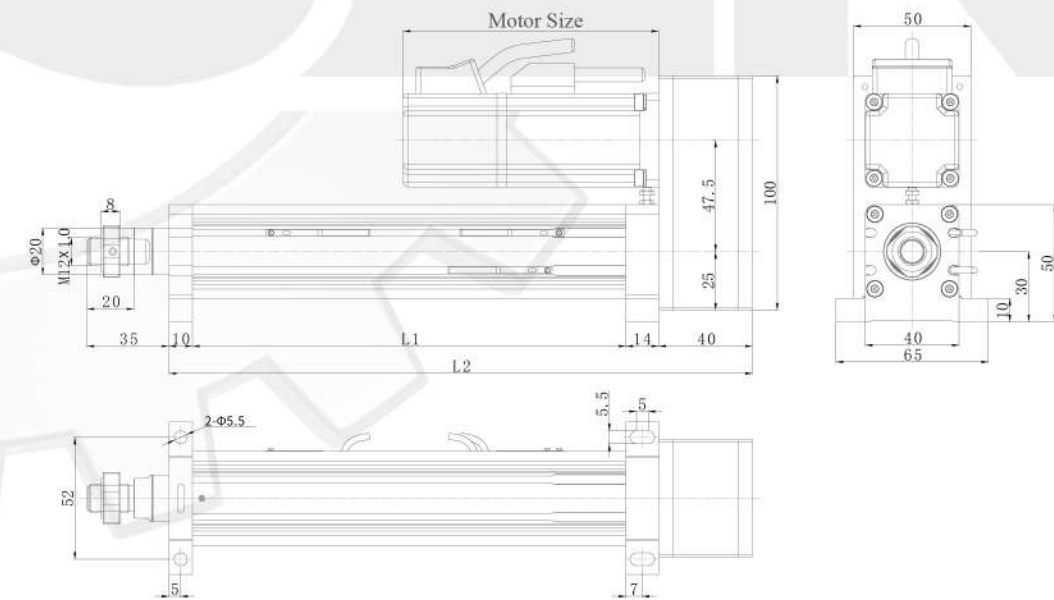

*. Dimensions are subject to change without notice



Specifications and Dimensions
KMZ50 Parameters for Standard Configurations
1) Basic Parameters

- (Note: The Push Load, Stroke and Speed of the Servo Electric Cylinders need to be combined with the actual use, and the three upper limits cannot be used in combination at the same time.) all size, easy installation and use, simple maintenance, low noise, long life, multiple safety protection measures.

Cylinder O.D. (mm)	Cylinder I.D. (mm)	Maximum Push Load	Stroke	Maximum Speed	Rotation Degree of Piston Rod	Limit Switches
53x53 mm	Φ40 mm	≤1.5KN	≤360 mm	≤500 mm/s	±0.3°	Magnetic Switches

2) Optional

Screw Lead	Ratio	Direct Motor		Planetary Gear Reducer
		Servo Motor Frame	Stepper Motor Frame	
5mm	1: 1.5: 2:	40, 60	57	N/A
10mm	1 1 1			

3) Screw Parameters

- (Note: The load of the screw is based on Stroke ≤300mm, and the Stroke >300mm needs to consult our technicians.)

Screw Model	Screw Type	Screw Diam.	Screw Lead	Dynamic Load Ca (kN)	Static Load Coa (kN)	Stiffness Kgf/μm
SFA1205-2.8	Ball Screw	12mm	5mm	6.4	12.9	19
SFA1210-2.8			10mm	6.2	12.9	

Screw Model	Ball Diam.	Screw Shaft	Slenderness Ratio	Accuracy Grade / Positioning Accuracy
SFA1205-2.8	2.5mm	8K3	1:30	C5/±0.01
SFA1210-2.8				

4) Bearing Parameters

Bearing Model	Dynamic Load Cr (kN)	Static Load Cor (kN)
Deep Groove Ball Bearing 6200-2RS	5.1	2.39

Specifications and Dimensions
5) Synchronous Wheel and Timing Belt Parameters

Ratio	Synchronous Wheels				Timing Belt		
	Drive Wheels		Driven Wheels		Center Distance	Circumference	Width
Model	Number of Teeth	Model	Number of Teeth				
1:1		32		32	60mm	216	15mm
1.5:1	3M15T27	32	3M15T23	48		240	
2:1		24		48		231	

6) Front Attachment Dimensions

Front Attachment	Clevis end		Fork end		Male Threaded end		Female Threaded end		Rod end	
	ΦA	ΦB	ΦC	C	D	E	F	H	G	M
Male Threaded end	Φ40	Φ25	—	30	50	3	10	—	22	M16x1.5
Female Threaded end	Φ40	Φ25	—	20	20	3	—	—	22	M10
Clevis end	Φ40	Φ25	Φ12	—	78	3	12	24	22	—
Rod end	Φ40	Φ25	Φ12	—	53	3	16	—	22	—
Fork end	Φ40	Φ25	Φ12	—	78	3	12	24	25.4	—

Specifications and Dimensions

KMZ50

• Note: When different motors are matched, the dimensions may change.

(P01) Front Flange: L1 = Stroke + 87mm, L2 = Stroke + 172mm

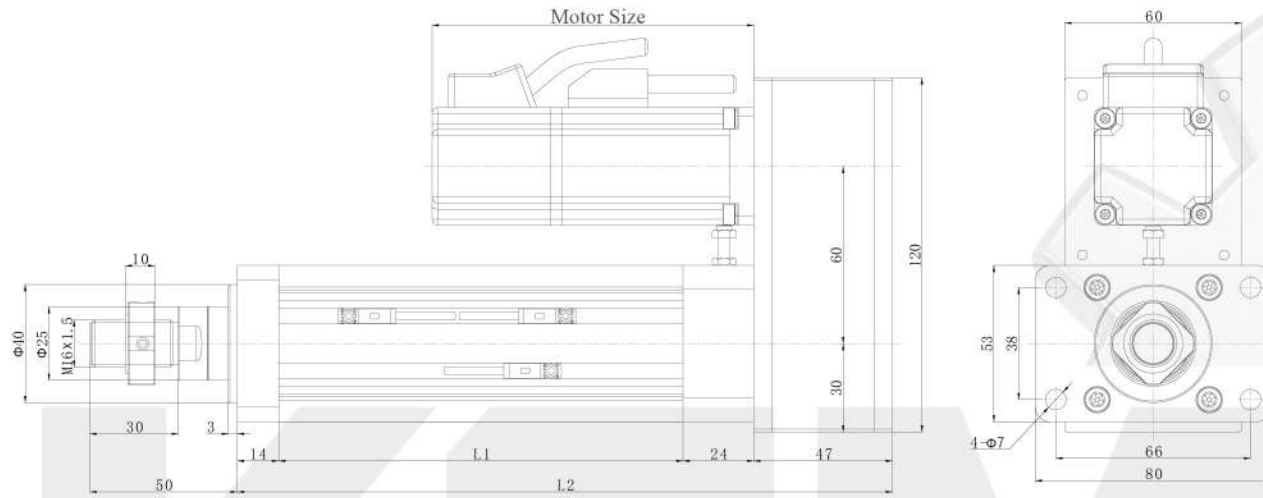

(P02) Rear Flange: L1 = Stroke + 87mm, L2 = Stroke + 172mm

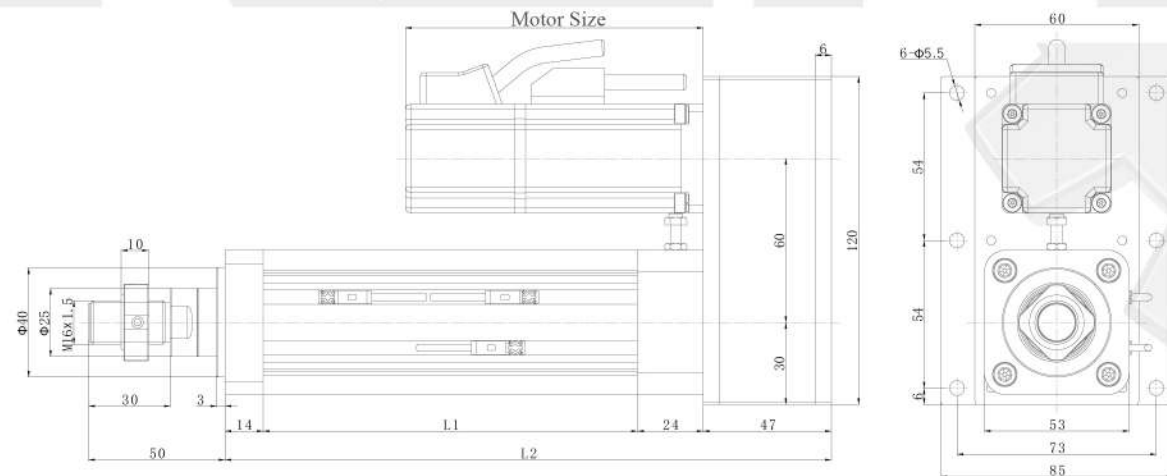

*. Dimensions are subject to change without notice



Specifications and Dimensions

KMZ50

• Note: When different motors are matched, the dimensions may change.

(P03) Trunnion: L1 = Stroke + 87mm, L2 = Stroke + 172mm

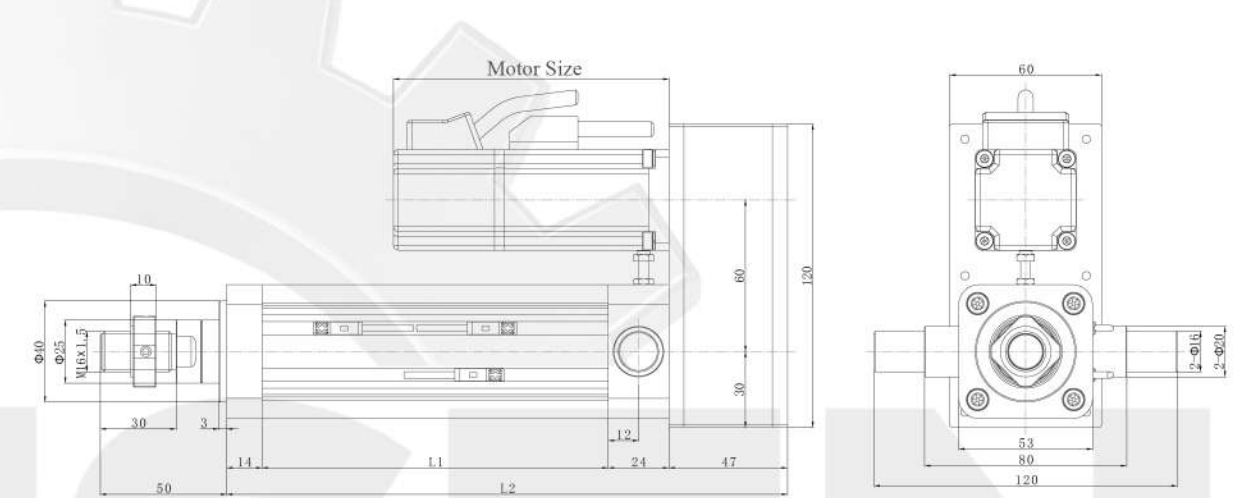

(P04) Side Flange: L1 = Stroke + 87mm, L2 = Stroke + 172mm

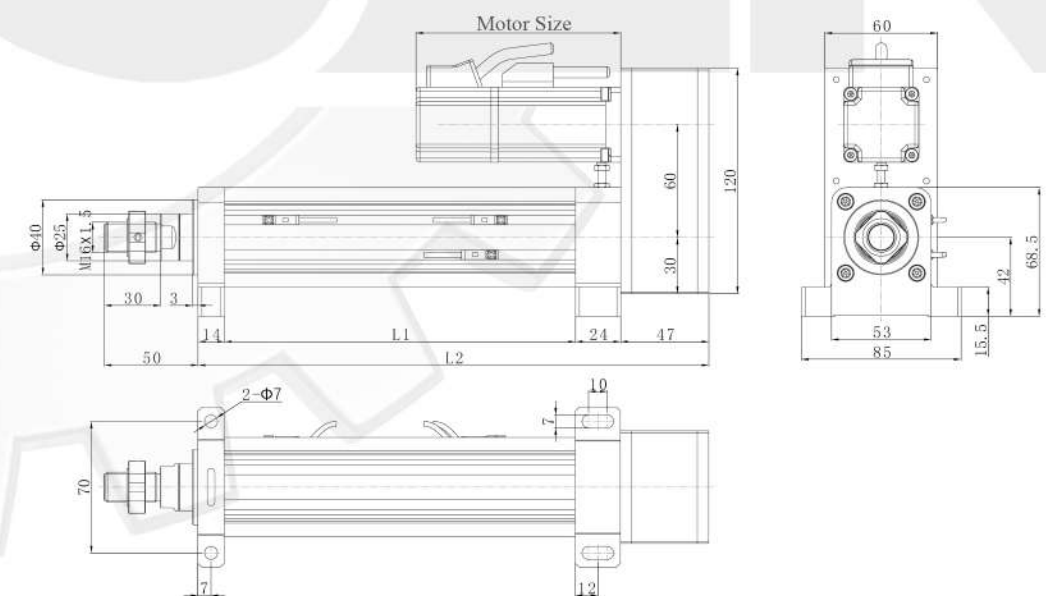

*. Dimensions are subject to change without notice



Specifications and Dimensions

KMZ50

• Note: When different motors are matched, the dimensions may change.

(P05) Rear Hinge: L1 = Stroke + 87mm, L2 = Stroke + 278mm

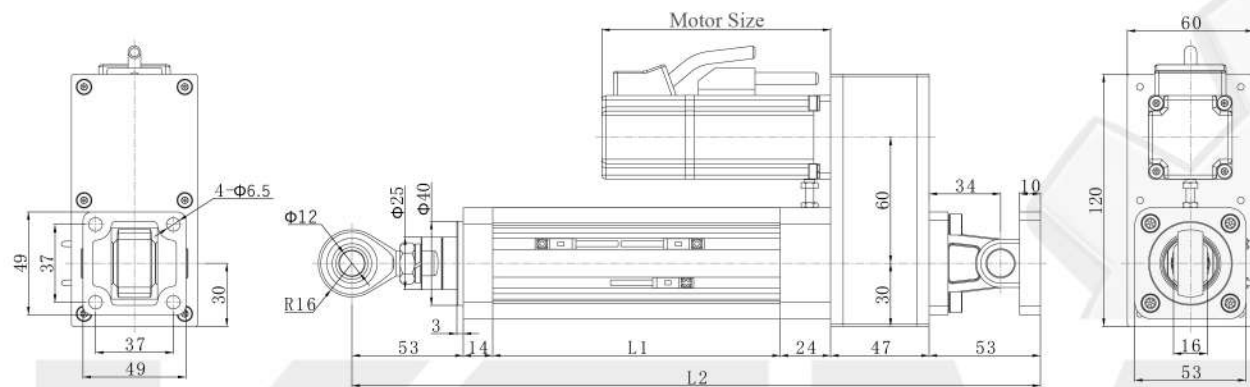

(P06) Guide Column Type: L1 = Stroke + 101mm, L2 = Stroke + 214mm

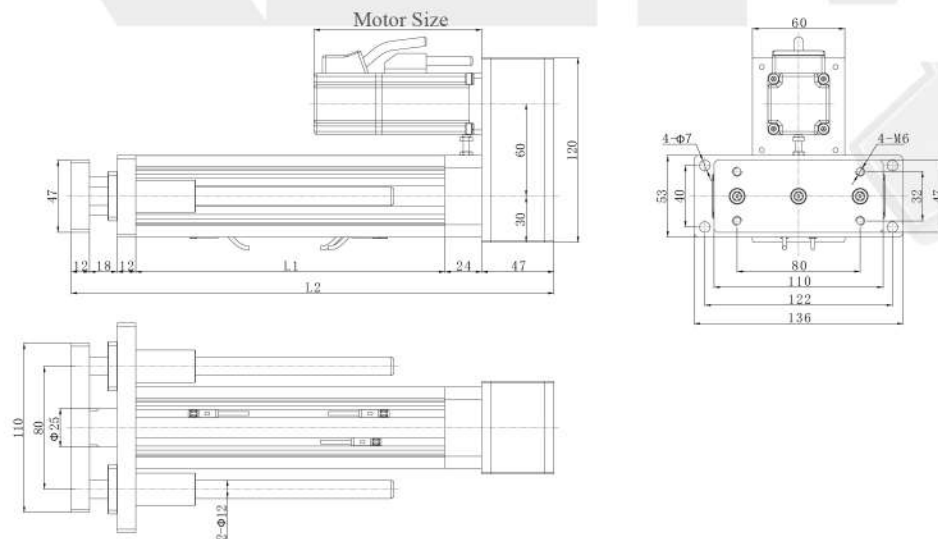

*. Dimensions are subject to change without notice



Specifications and Dimensions

KMZ50

• Note: When different motors are matched, the dimensions may change.

(P07) Front Lock Type: L1 = Stroke + 101mm, L2 = Stroke + 172mm

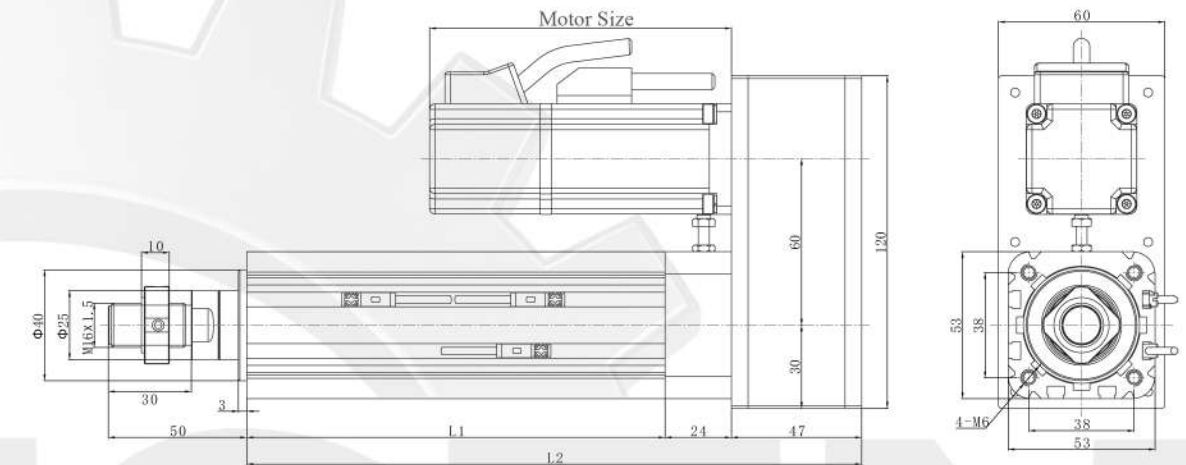

*. Dimensions are subject to change without notice



Specifications and Dimensions
KMZ60 Parameters for Standard Configurations
1) Basic Parameters

- (Note: The Push Load, Stroke and Speed of the Servo Electric Cylinders need to be combined with the actual use, and the three upper limits cannot be used in combination at the same time.) all size, easy installation and use, simple maintenance, low noise, long life, multiple safety protection measures.

Cylinder O.D. (mm)	Cylinder I.D. (mm)	Maximum Push Load	Stroke	Maximum Speed	Rotation Degree of Piston Rod	Limit Switches
61x61 mm	Φ50 mm	≤2.7KN	≤480 mm	≤500 mm/s	±0.3°	Magnetic Switches

2) Optional

Screw Lead	Ratio	Direct Motor		Planetary Gear Reducer
		Servo Motor Frame	Stepper Motor Frame	
5mm				
10mm	1: 1.5: 2:	60	57	N/A
16mm	1 1 1			
20mm				

3) Screw Parameters

- (Note: The load of the screw is based on Stroke ≤300mm, and the Stroke >300mm needs to consult our technicians.)

Screw Model	Screw Type	Screw Diam.	Screw Lead	Dynamic Load Ca (kN)	Static Load Coa (kN)	Stiffness Kgf/μm
SFNU1605-4	Ball Screw	16mm	5mm	13.5	29.9	32
SFNU1610-3			10mm	10.8	23.5	26
SFA1616-1.8			16mm	5.4	11.1	14
SFA1620-1.8			20mm	5.4	11.4	

Screw Model	Ball Diam.	Screw Shaft	Slenderness Ratio	Accuracy Grade / Positioning Accuracy
SFNU1605-4	3.175mm	10K3	1:30	C5/±0.01
SFNU1610-3				
SFA1616-1.8	2.778mm			
SFA1620-1.8				

4) Bearing Parameters

Bearing Model	Dynamic Load Cr (kN)	Static Load Cor (kN)
Deep Groove Ball Bearing 6301-ZZ	9.7	4.2

Specifications and Dimensions
5) Synchronous Wheel and Timing Belt Parameters

Ratio	Synchronous Wheels				Timing Belt		
	Drive Wheels		Driven Wheels		Center Distance	Circumference	Width
	Model	Number of Teeth	Model	Number of Teeth			
1:1		36		36	85mm	350	15mm
1.5:1	5M15T29	24	5M15T29	36		320	
2:1		24		48		355	

6) Front Attachment Dimensions

Front Attachment	• Clevis end			• Fork end						
	ΦA	ΦB	ΦC	C	D	E	F	H	G	M
Male Threaded end	Φ50	Φ35	—	30	50	3	11	—	33	M20x1.5
Female Threaded end	Φ50	Φ35	—	30	20	3	—	—	33	M16
Clevis end	Φ50	Φ35	Φ16		95	3	16	32	33	—
Rod end	Φ50	Φ35	Φ16		61	3	21	—	33	—
Fork end	Φ50	Φ35	Φ16		95	3	16	32	32	—

Specifications and Dimensions

KMZ60

• Note: When different motors are matched, the dimensions may change.

(P01) Front Flange: L1 = Stroke + 85mm, L2 = Stroke + 192mm

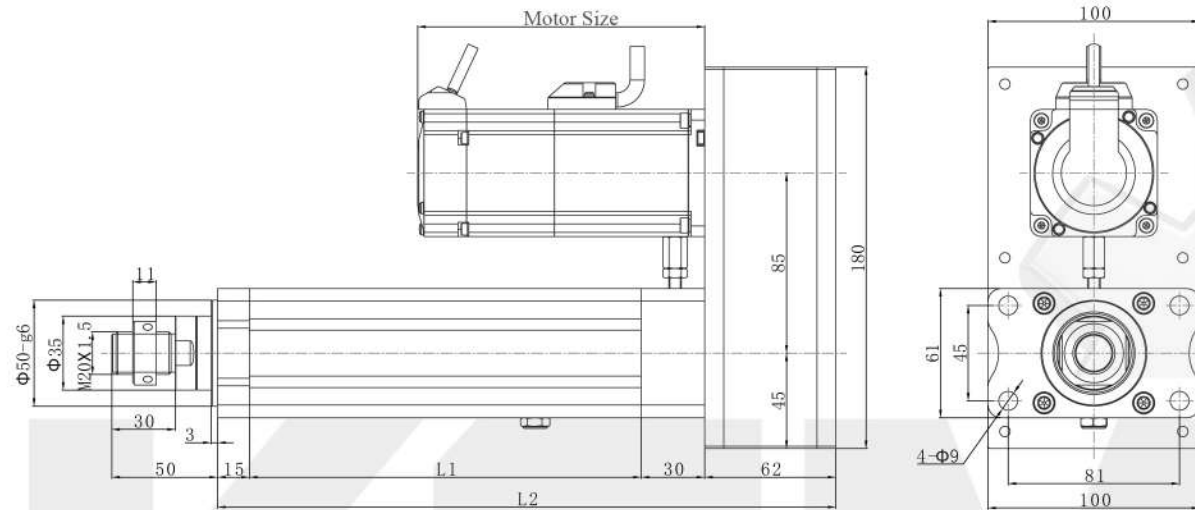

(P02) Rear Flange: L1 = Stroke + 85mm, L2 = Stroke + 192mm

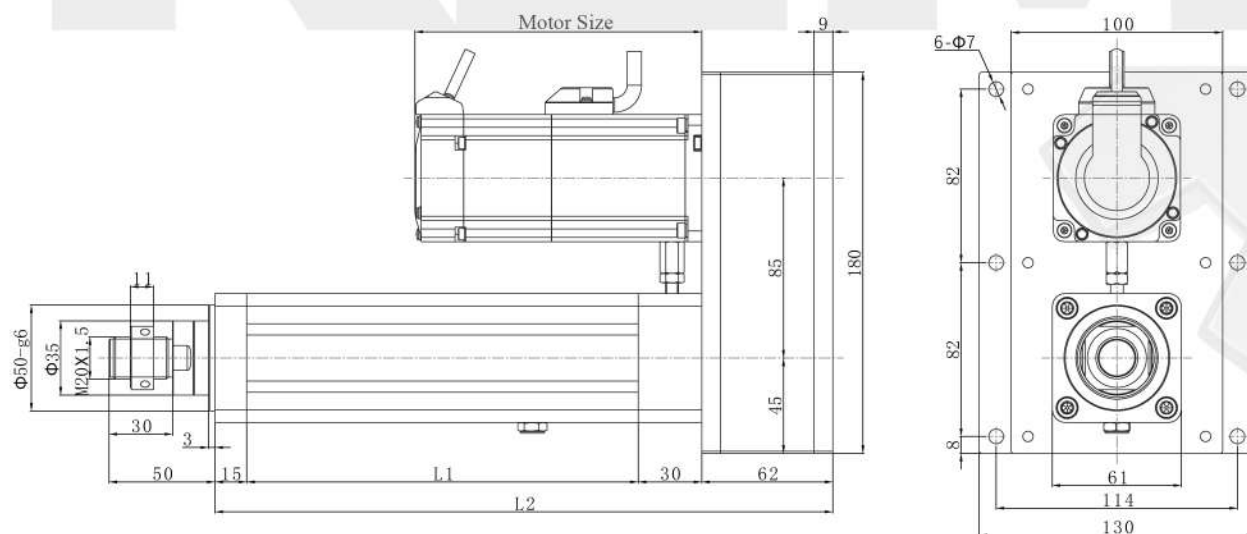

*. Dimensions are subject to change without notice



Specifications and Dimensions

KMZ60

• Note: When different motors are matched, the dimensions may change.

(P03) Trunnion: L1 = Stroke + 85mm, L2 = Stroke + 192mm

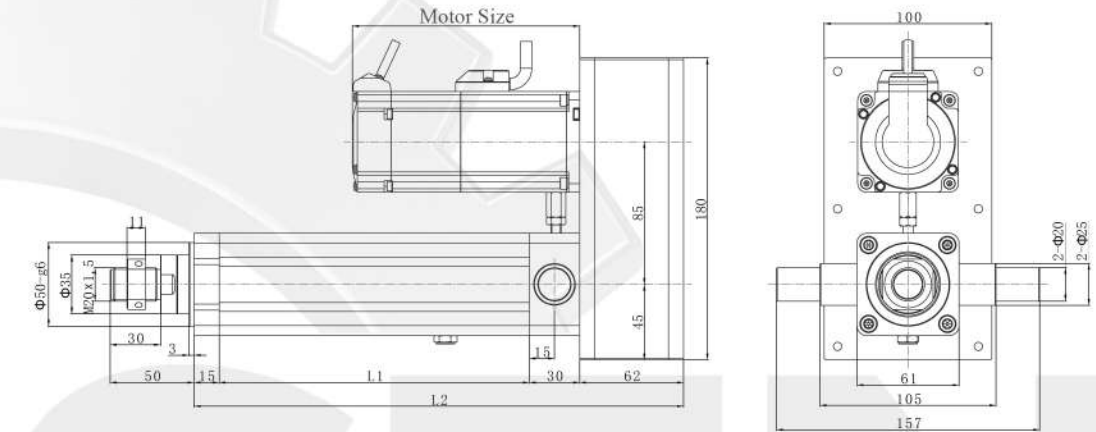

(P04) Side Flange: L1 = Stroke + 85mm, L2 = Stroke + 192mm

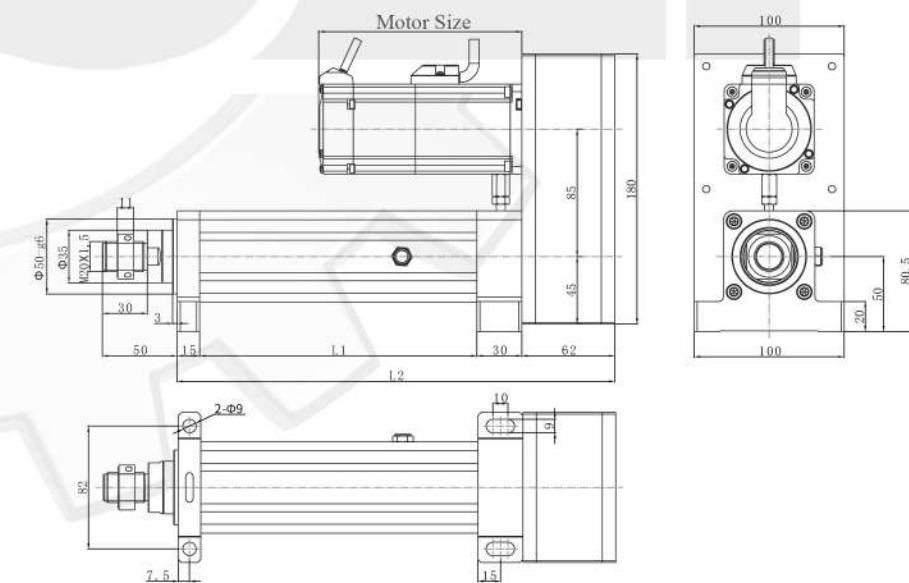

*. Dimensions are subject to change without notice



Specifications and Dimensions

KMZ60

• Note: When different motors are matched, the dimensions may change.

(P05) Rear Hinge: L1 = Stroke + 85mm, L2 = Stroke + 306mm

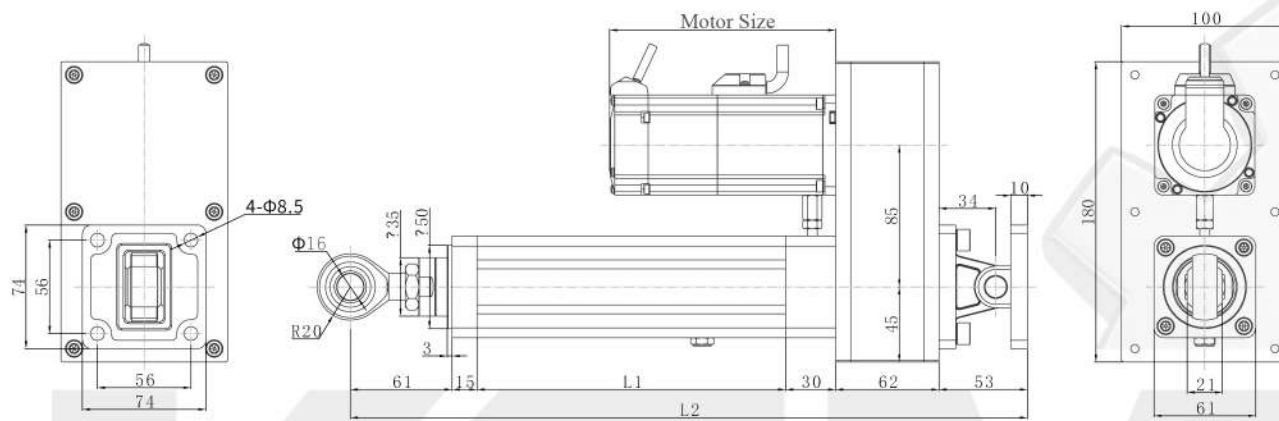

(P06) Guide Column Type: L1 = Stroke + 100mm, L2 = Stroke + 241mm

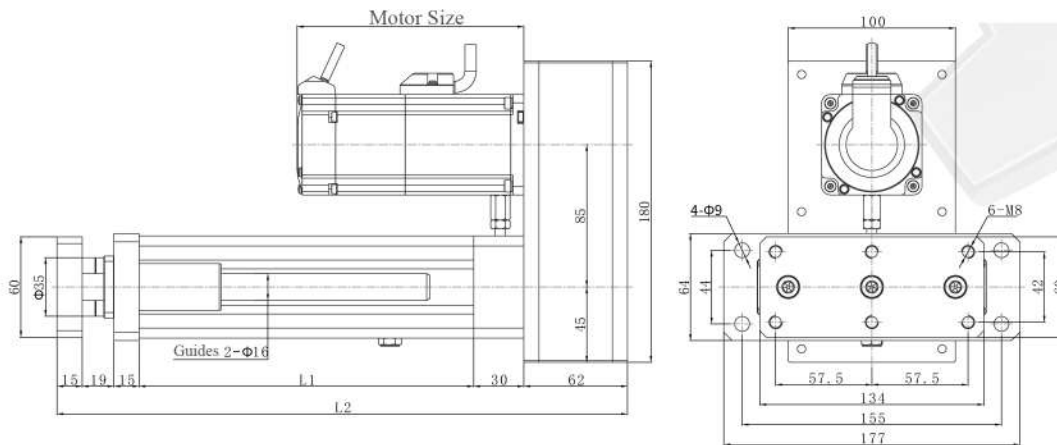

*. Dimensions are subject to change without notice

Specifications and Dimensions

KMZ60

• Note: When different motors are matched, the dimensions may change.

(P07) Front Lock Type: L1 = Stroke + 100mm, L2 = Stroke + 192mm

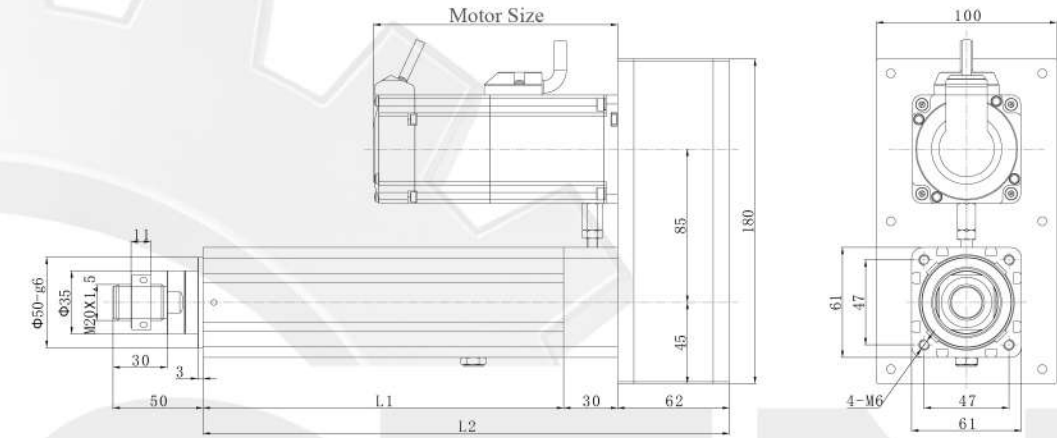

*. Dimensions are subject to change without notice

Specifications and Dimensions
KMZ60Z Parameters for Standard Configurations
1) Basic Parameters

- (Note: The Push Load, Stroke and Speed of the Servo Electric Cylinders need to be combined with the actual use, and the three upper limits cannot be used in combination at the same time.) all size, easy installation and use, simple maintenance, low noise, long life, multiple safety protection measures.

Cylinder O.D. (mm)	Cylinder I.D. (mm)	Maximum Push Load	Stroke	Maximum Speed	Rotation Degree of Piston Rod	Limit Switches
61x61 mm	Φ50 mm	≤5KN	≤480 mm	≤500 mm/s	±0.3°	Magnetic Switches

2) Optional

Screw Lead	Ratio	Direct Motor		Planetary Gear Reducer
		Servo Motor Frame	Stepper Motor Frame	
5mm				
10mm	1: 1.5: 2:			
16mm	1 1 1	80	86	60
20mm				

3) Screw Parameters

- (Note: The load of the screw is based on Stroke ≤300mm, and the Stroke >300mm needs to consult our technicians.)

Screw Model	Screw Type	Screw Diam.	Screw Lead	Dynamic Load Ca (kN)	Static Load Coa (kN)	Stiffness Kg/μm
SFNU1605-4	Ball Screw	16mm	5mm	13.5	29.9	32
SFNU1610-3			10mm	10.8	23.5	26
SFA1616-1.8			16mm	5.4	11.1	14
SFA1620-1.8			20mm	5.4	11.4	

Screw Model	Ball Diam.	Screw Shaft	Slenderness Ratio	Accuracy Grade / Positioning Accuracy
SFNU1605-4	3.175mm	14K5	1:30	C5/±0.01
SFNU1610-3				
SFA1616-1.8	2.778mm			
SFA1620-1.8				

4) Bearing Parameters

Bearing Model	Dynamic Load Cr (kN)	Static Load Cor (kN)
Deep Groove Ball Bearing 6004-ZZ	9.38	5.03
Thrust Ball Bearing 51105	19.6	37

Specifications and Dimensions
5) Synchronous Wheel and Timing Belt Parameters

Ratio	Synchronous Wheels				Timing Belt		
	Drive Wheels		Driven Wheels		Center Distance	Circumference	Width
	Model	Number of Teeth	Model	Number of Teeth			
1:1		36		36	85mm	350	20mm
1.5:1	5M20T34	24	5M20T30	36		320	
2:1		24		48		355	

6) Front Attachment Dimensions

Front Attachment	Clevis end			Fork end			Male Threaded end			Female Threaded end			Rod end		
	ΦA	ΦB	ΦC	C	D	E	F	H	G	M					
Male Threaded end	Φ50	Φ35	—	30	50	3	11	—	33	M20x1.5					
Female Threaded end	Φ50	Φ35	—	30	20	3	—	—	33	M16					
Clevis end	Φ50	Φ35	Φ16		95	3	16	32	33	—					
Rod end	Φ50	Φ35	Φ16		61	3	21	—	33	—					
Fork end	Φ50	Φ35	Φ16		95	3	16	32	32	—					

Specifications and Dimensions

KMZ60Z

• Note: When different motors are matched, the dimensions may change.

(P01) Front Flange: $L1 = \text{Stroke} + 85\text{mm}$, $L2 = \text{Stroke} + 192\text{mm}$

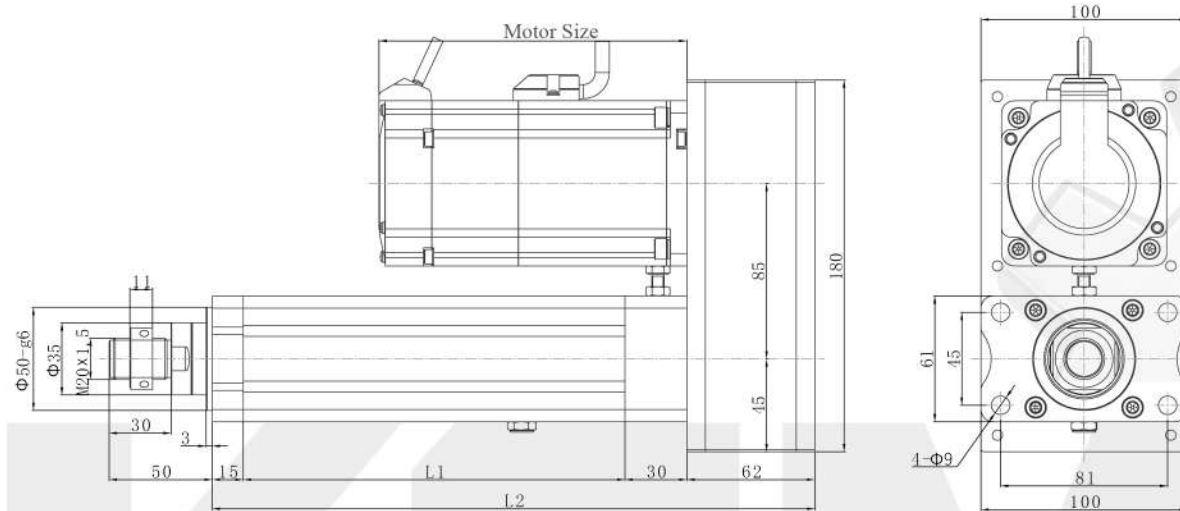

(P02) Rear Flange: $L1 = \text{Stroke} + 85\text{mm}$, $L2 = \text{Stroke} + 192\text{mm}$

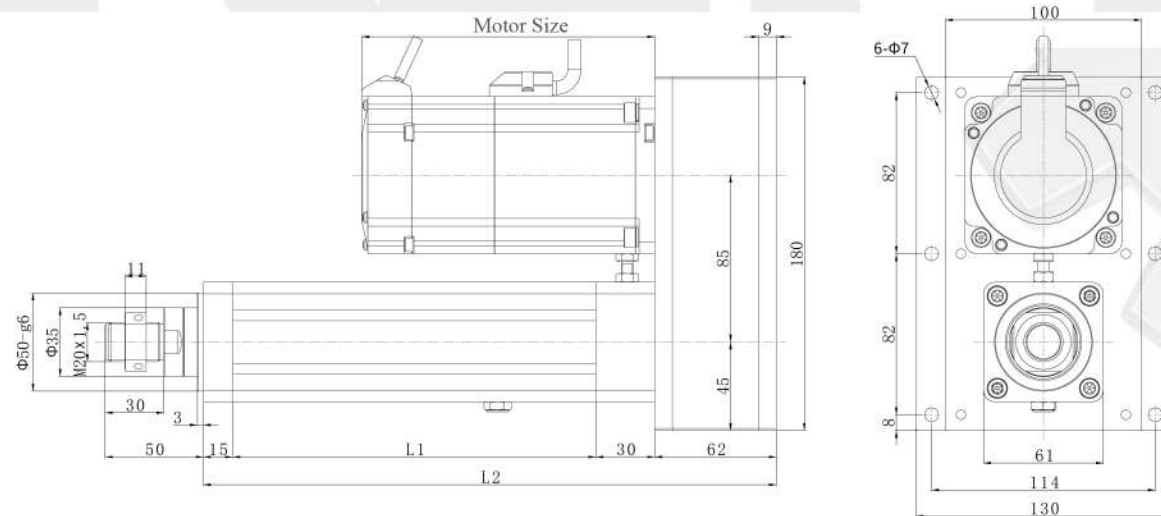

*. Dimensions are subject to change without notice



Specifications and Dimensions

KMZ60Z

• Note: When different motors are matched, the dimensions may change.

(P03) Trunnion: $L1 = \text{Stroke} + 85\text{mm}$, $L2 = \text{Stroke} + 192\text{mm}$

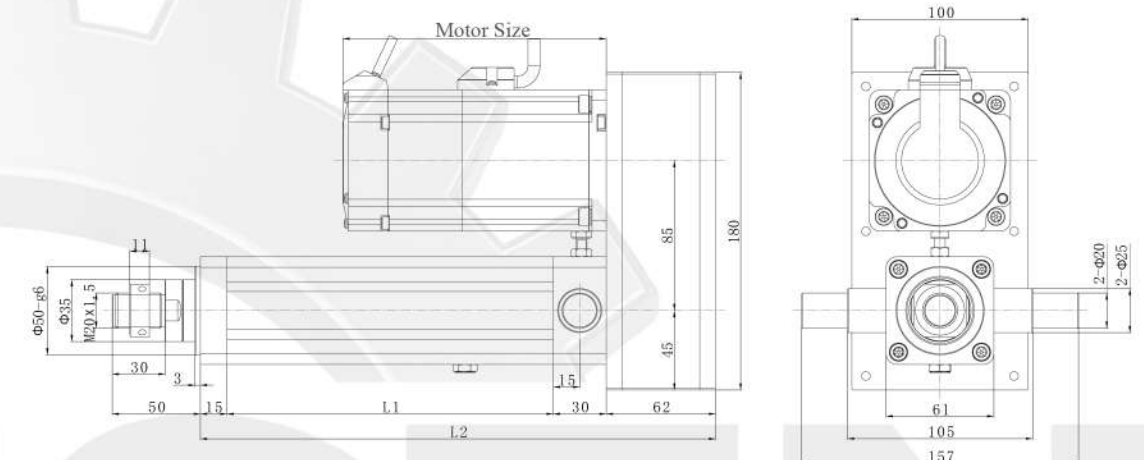

(P04) Side Flange: $L1 = \text{Stroke} + 85\text{mm}$, $L2 = \text{Stroke} + 192\text{mm}$

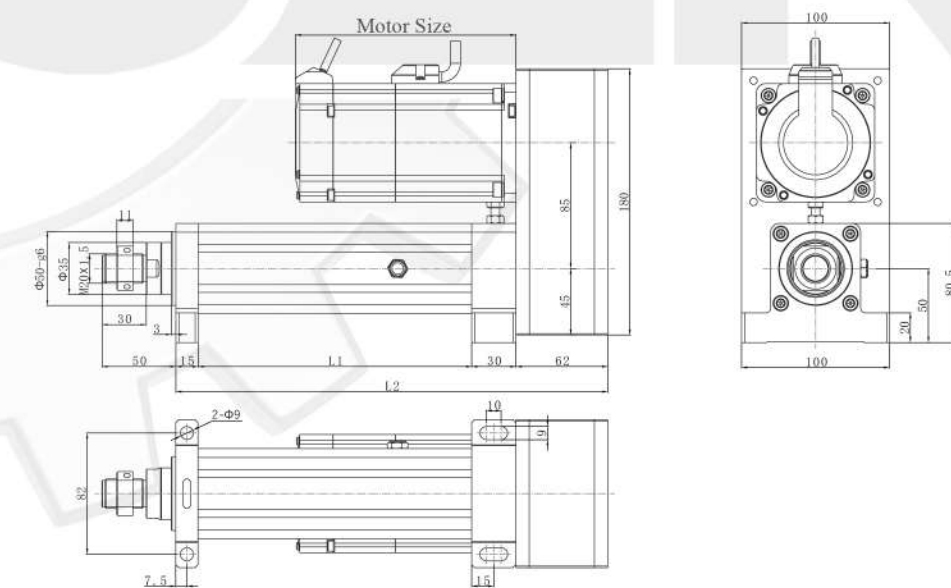

*. Dimensions are subject to change without notice



Specifications and Dimensions

KMZ60Z

• Note: When different motors are matched, the dimensions may change.

(P05) Rear Hinge: L1 = Stroke + 85mm, L2 = Stroke + 306mm

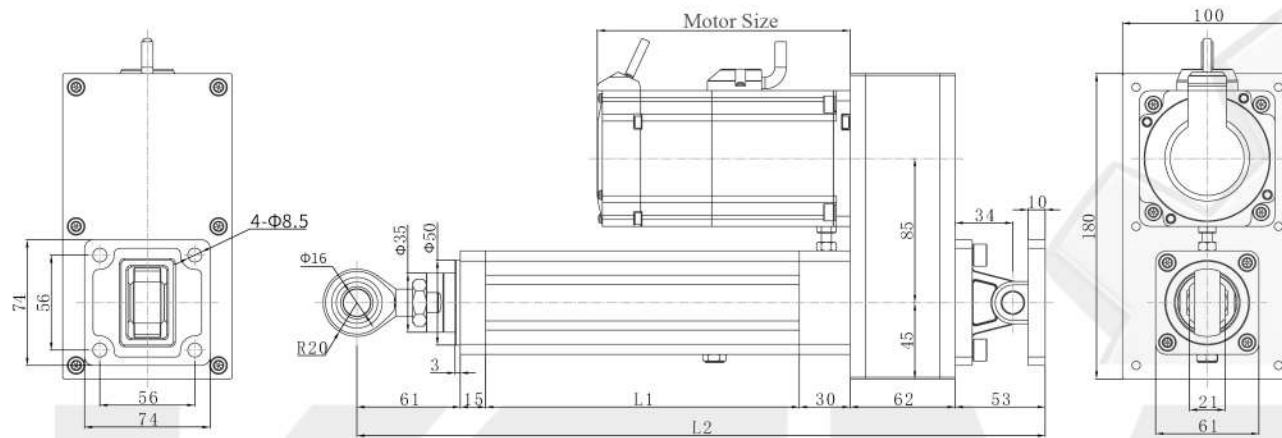

(P06) Guide Column Type: L1 = Stroke + 100mm, L2 = Stroke + 241mm

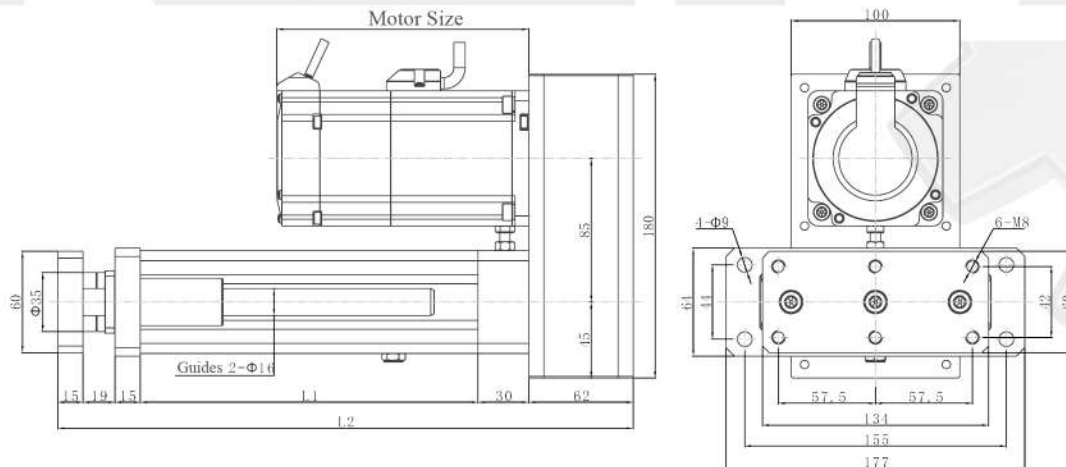

*. Dimensions are subject to change without notice

Specifications and Dimensions

KMZ60Z

• Note: When different motors are matched, the dimensions may change.

(P07) Front Lock Type: L1 = Stroke + 100mm, L2 = Stroke + 192mm

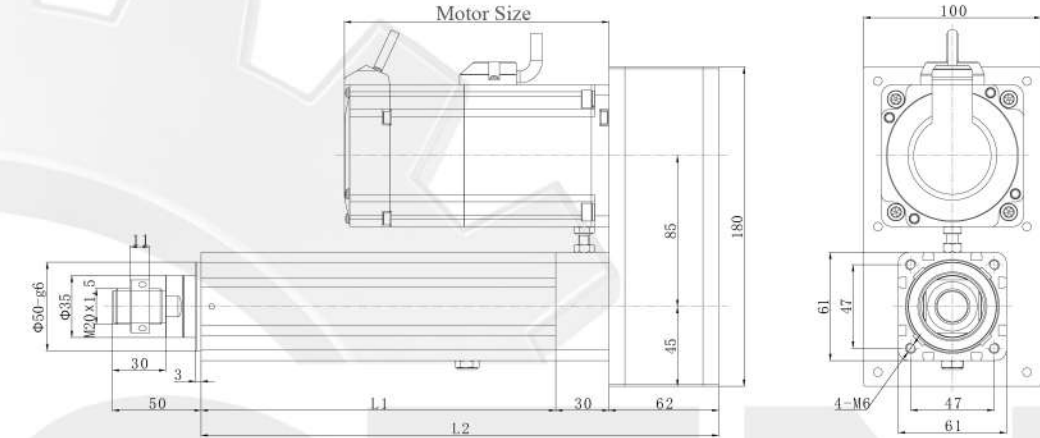

*. Dimensions are subject to change without notice

Specifications and Dimensions
KMZ75 Parameters for Standard Configurations
1) Basic Parameters

- (Note: The Push Load, Stroke and Speed of the Servo Electric Cylinders need to be combined with the actual use, and the three upper limits cannot be used in combination at the same time.) all size, easy installation and use, simple maintenance, low noise, long life, multiple safety protection measures.

Cylinder O.D. (mm)	Cylinder I.D. (mm)	Maximum Push Load	Stroke	Maximum Speed	Rotation Degree of Piston Rod	Limit Switches
75x75 mm	Φ63 mm	≤6.8kN	≤600 mm	≤500 mm/s	±0.3°	Magnetic Switches

2) Optional

Screw Lead	Ratio	Direct Motor		Planetary Gear Reducer
		Servo Motor Frame	Stepper Motor Frame	
5mm	1: 1.5: 2: 1 1 1	60,80	86	N/A
10mm				
20mm				

3) Screw Parameters

- (Note: The load of the screw is based on Stroke ≤300mm, and the Stroke >300mm needs to consult our technicians.)

Screw Model	Screw Type	Screw Diam.	Screw Lead	Dynamic Load Ca (kN)	Static Load Coa (kN)	Stiffness Kgf/μm
SFNU2005-4	Ball Screw	20mm	5mm	15.2	38	39
SFA2010-3.8			10mm	14.8	38	40
SFA2020-1.8			20mm	7.4	17.2	19

Screw Model	Ball Diam.	Screw Shaft	Slenderness Ratio	Accuracy Grade / Positioning Accuracy
SFNU2005-4	3.175mm	12K4	1:30	C5/±0.01
SFA2010-3.8				
SFA2020-1.8				

4) Bearing Parameters

Bearing Model	Dynamic Load Cr (kN)	Static Load Cor (kN)
Tapered Roller Bearing 30302x2	23.6	21.1

Specifications and Dimensions
5) Synchronous Wheel and Timing Belt Parameters

Ratio	Synchronous Wheels				Timing Belt		
	Drive Wheels		Driven Wheels		Center Distance	Circumference	Width
	Model	Number of Teeth	Model	Number of Teeth			
1:1		36		36	85mm	350	15mm
1.5:1	5M15T29	24	5M15T29	36		320	
2:1		24		48		355	

6) Front Attachment Dimensions

Front Attachment	Clevis end		Fork end		Male Threaded end		Female Threaded end		Rod end	
	ΦA	ΦB	ΦC	C	D	E	F	H	G	M
Male Threaded end	Φ60	Φ45	—	40	65	3	12	—	41	M30x1.5
Female Threaded end	Φ60	Φ45	—	40	25	3	—	—	41	M20
Clevis end	Φ60	Φ45	Φ20	—	118	3	20	40	41	—
Rod end	Φ60	Φ45	Φ20	—	72	3	25	—	41	—
Fork end	Φ60	Φ45	Φ20	—	118	3	20	40	44.4	—

Specifications and Dimensions

KMZ75

• Note: When different motors are matched, the dimensions may change.

(P05) Rear Hinge: L1 = Stroke + 104mm, L2 = Stroke + 341mm

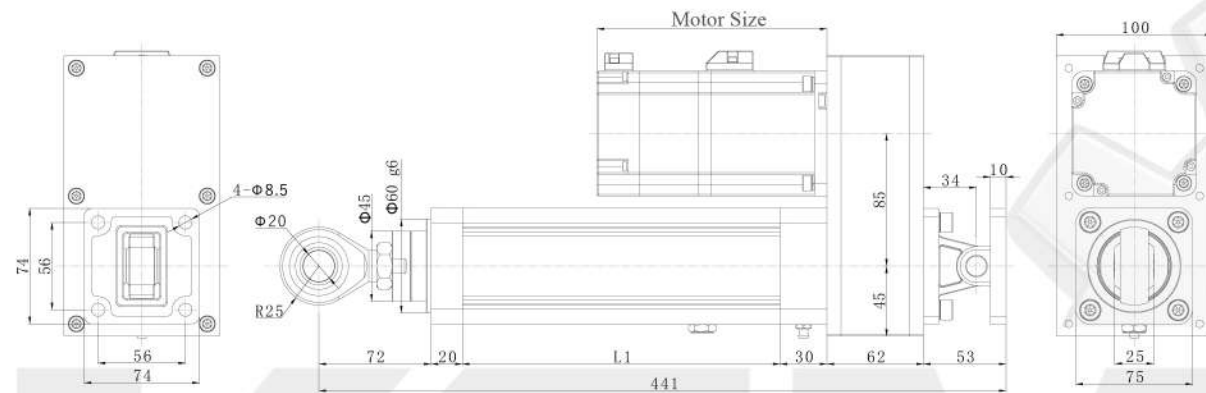

(P06) Guide Column Type: L1 = Stroke + 104mm, L2 = Stroke + 277mm

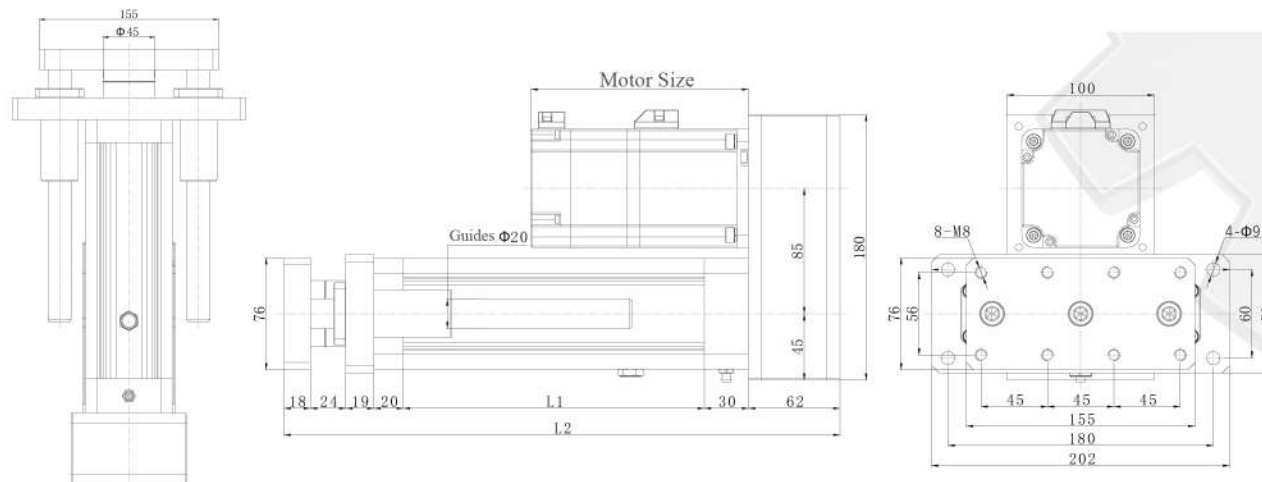

*. Dimensions are subject to change without notice



Specifications and Dimensions

KMZ75

• Note: When different motors are matched, the dimensions may change.

(P07) Front Lock Type: L1 = Stroke + 104mm, L2 = Stroke + 226mm

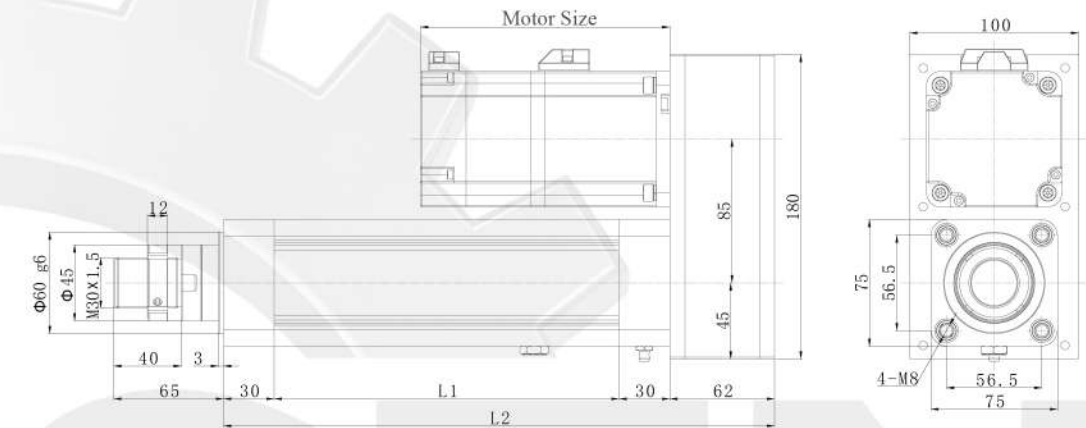

*. Dimensions are subject to change without notice



Specifications and Dimensions

KMZ75Z Parameters for Standard Configurations

1) Basic Parameters

- (Note: The Push Load, Stroke and Speed of the Servo Electric Cylinders need to be combined with the actual use, and the three upper limits cannot be used in combination at the same time.) all size, easy installation and use, simple maintenance, low noise, long life, multiple safety protection measures.

Cylinder O.D. (mm)	Cylinder I.D. (mm)	Maximum Push Load	Stroke	Maximum Speed	Rotation Degree of Piston Rod	Limit Switches
75x75 mm	Φ63 mm	≤8KN	≤600 mm	≤500 mm/s	±0.3°	Magnetic Switches

2) Optional

Screw Lead	Ratio	Direct Motor		Planetary Gear Reducer
		Servo Motor Frame	Stepper Motor Frame	
5mm	1: 1.5: 2: 1 1 1	100, 130	N/A	60, 90
10mm				
20mm				

3) Screw Parameters

- (Note: The load of the screw is based on Stroke ≤300mm, and the Stroke >300mm needs to consult our technicians.)

Screw Model	Screw Type	Screw Diam.	Screw Lead	Dynamic Load Ca (kN)	Static Load Coa (kN)	Stiffness Kgf/μm
SFNU2005-4	Ball Screw	20mm	5mm	15.2	38	39
SFA2010-3.8			10mm	14.8	38	40
SFA2020-1.8			20mm	7.4	17.2	19

Screw Model	Ball Diam.	Screw Shaft	Slenderness Ratio	Accuracy Grade / Positioning Accuracy
SFNU2005-4	3.175mm	22K6	1:30	C5/±0.01
SFA2010-3.8				
SFA2020-1.8				

4) Bearing Parameters

Bearing Model	Dynamic Load Cr (kN)	Static Load Cor (kN)
Deep Groove Ball Bearing 6206-ZZ	19.5	11.3
Thrust Ball Bearing 51206	29.3	58

Specifications and Dimensions

5) Synchronous Wheel and Timing Belt Parameters

Ratio	Synchronous Wheels				Timing Belt		
	Drive Wheels		Driven Wheels		Center Distance	Circumference	Width
	Model	Number of Teeth	Model	Number of Teeth			
1:1		40		40	110mm	420	25mm
1.5:1	5M25T42	30	5M25T42	45		410	
2:1		30		60		450	

6) Front Attachment Dimensions

Front Attachment	Clevis end			Fork end			Male Threaded end			Female Threaded end			Rod end		
	ΦA	ΦB	ΦC	C	D	E	F	H	G	M					
Male Threaded end	Φ60	Φ45	—	40	65	3	12	—	41	M30x1.5					
Female Threaded end	Φ60	Φ45	—	40	25	3	—	—	41	M20					
Clevis end	Φ60	Φ45	Φ20		118	3	20	40	41	—					
Rod end	Φ60	Φ45	Φ20		72	3	25	—	41	—					
Fork end	Φ60	Φ45	Φ20		118	3	20	40	44.4	—					

Specifications and Dimensions

KMZ75Z

• Note: When different motors are matched, the dimensions may change.

(P01) Front Flange: L1 = Stroke + 104mm, L2 = Stroke + 253mm

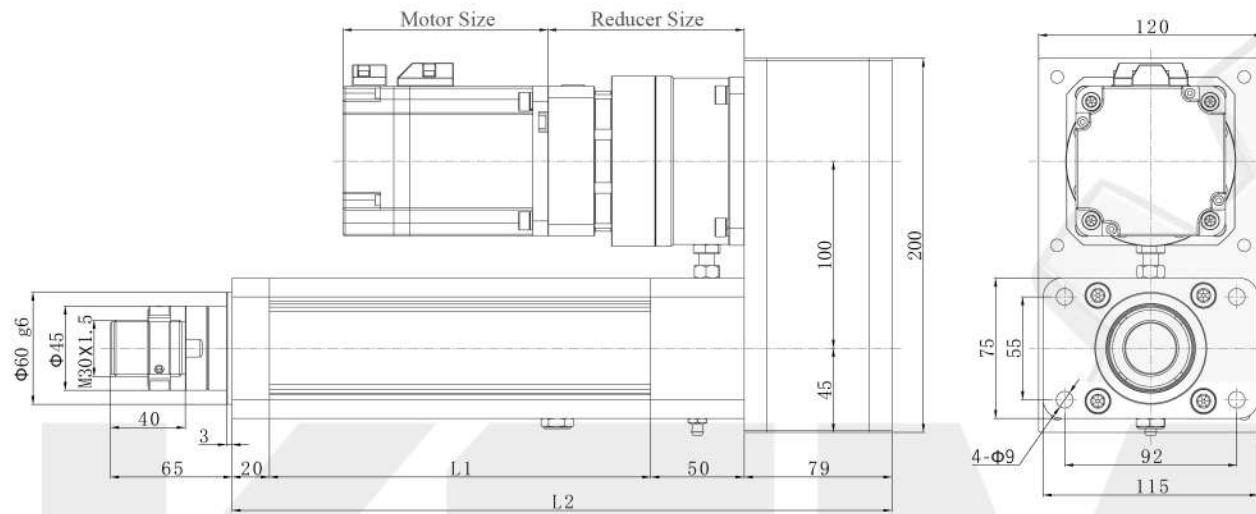

(P02) Rear Flange: L1 = Stroke + 104mm, L2 = Stroke + 253mm

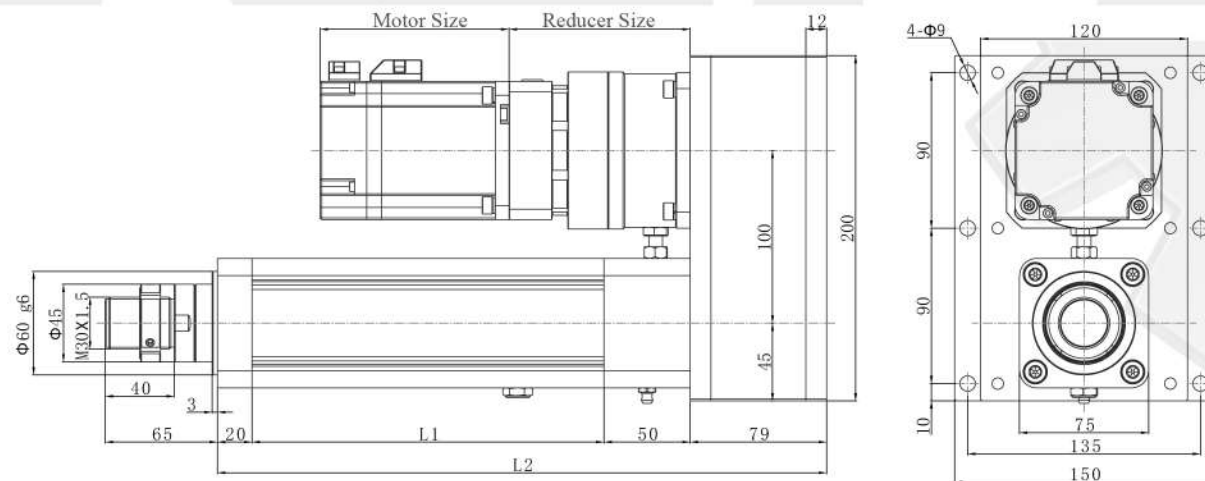

*. Dimensions are subject to change without notice



Specifications and Dimensions

KMZ75Z

• Note: When different motors are matched, the dimensions may change.

(P03) Trunnion: L1 = Stroke + 104mm, L2 = Stroke + 253mm

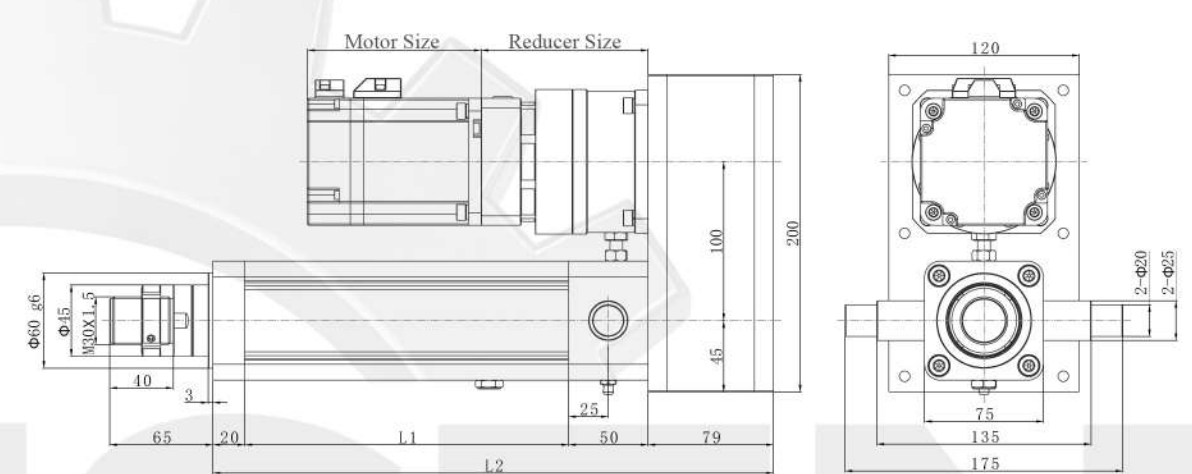

(P04) Side Flange: L1 = Stroke + 104mm, L2 = Stroke + 253mm

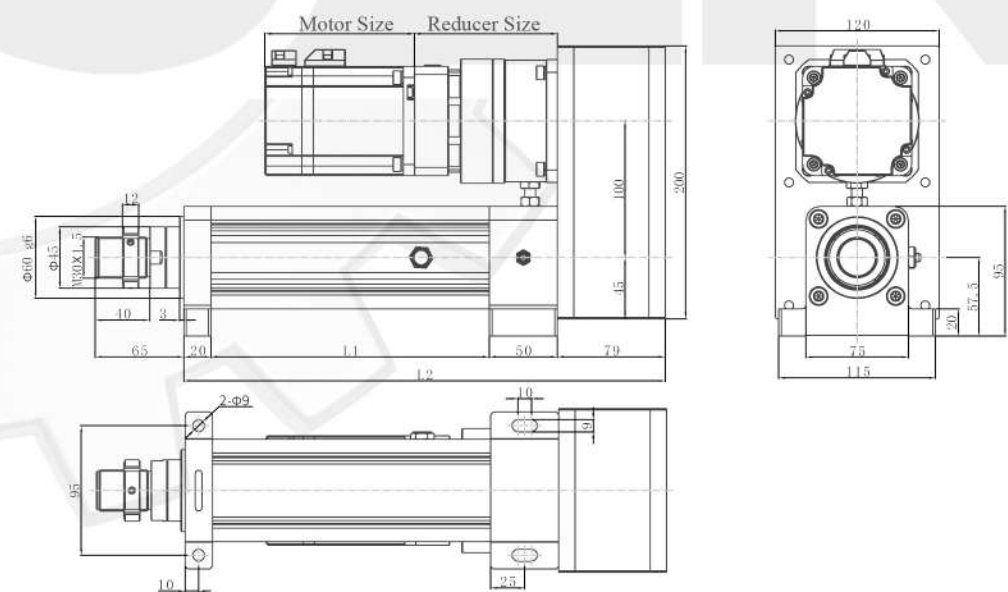

*. Dimensions are subject to change without notice



Specifications and Dimensions

KMZ75Z

• Note: When different motors are matched, the dimensions may change.

(P05) Rear Hinge: L1 = Stroke + 104mm, L2 = Stroke + 405mm

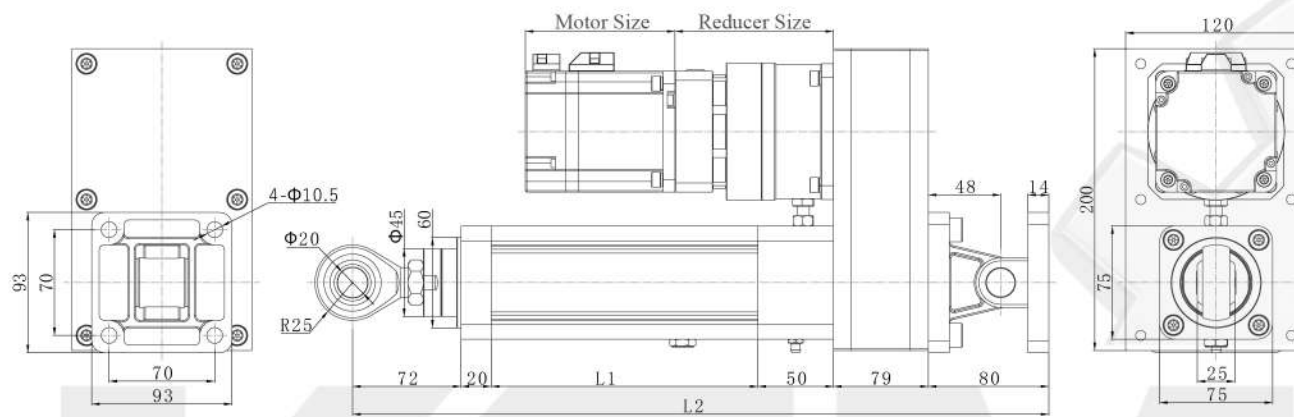

(P06) Guide Column Type: L1 = Stroke + 104mm, L2 = Stroke + 314mm

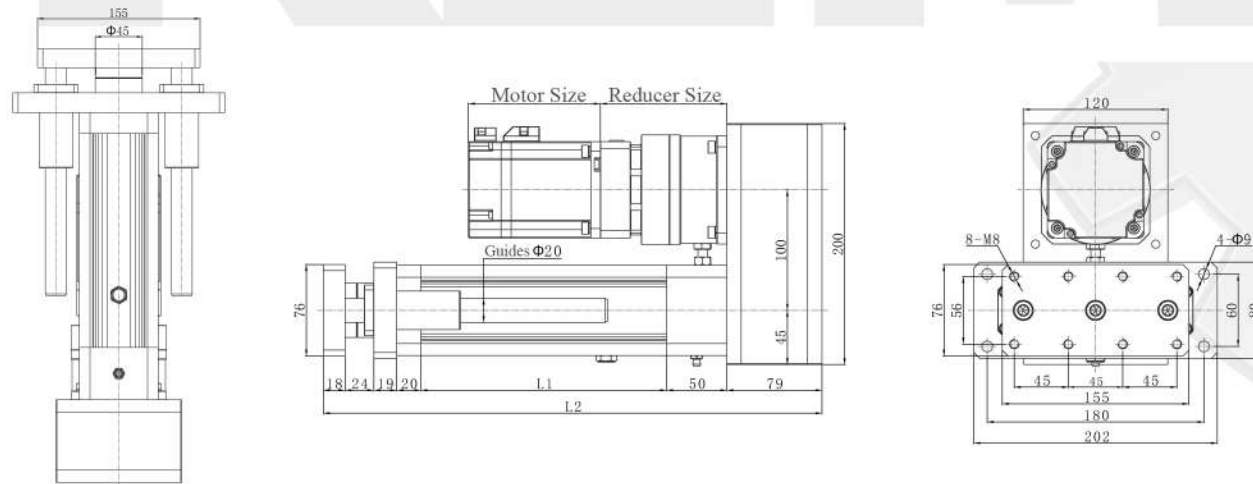

*. Dimensions are subject to change without notice

Specifications and Dimensions

KMZ75Z

• Note: When different motors are matched, the dimensions may change.

(P07) Front Lock Type: L1 = Stroke + 104mm, L2 = Stroke + 263mm

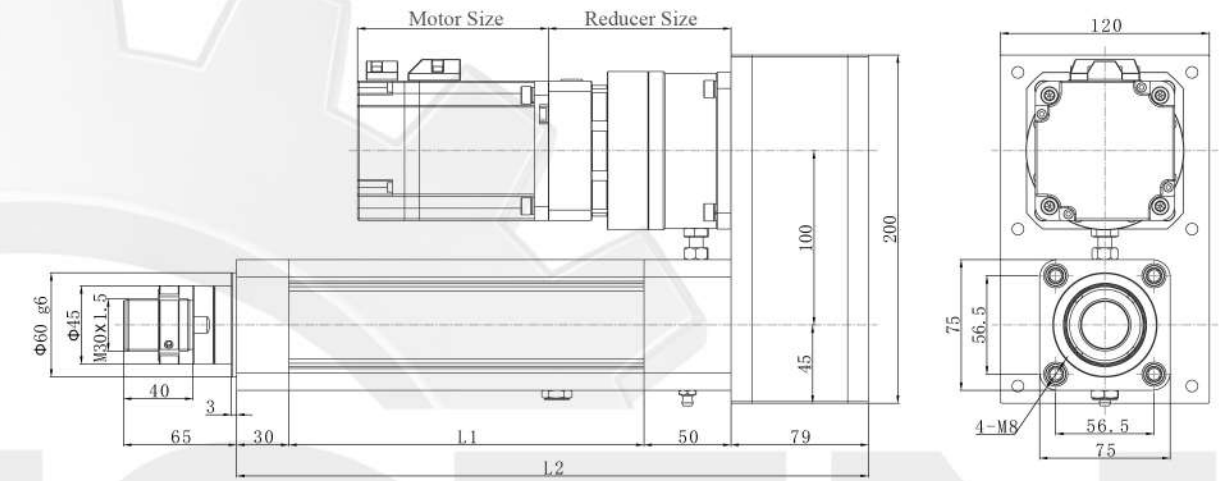

*. Dimensions are subject to change without notice

Specifications and Dimensions
KMZ80 Parameters for Standard Configurations
1) Basic Parameters

- (Note: The Push Load, Stroke and Speed of the Servo Electric Cylinders need to be combined with the actual use, and the three upper limits cannot be used in combination at the same time.) all size, easy installation and use, simple maintenance, low noise, long life, multiple safety protection measures.

Cylinder O.D. (mm)	Cylinder I.D. (mm)	Maximum Push Load	Stroke	Maximum Speed	Rotation Degree of Piston Rod	Limit Switches
80x80 mm	Φ65 mm	≤20KN	≤750 mm	≤1000 mm/s	±0.3°	Magnetic Switches

2) Optional

Screw Lead	Ratio	Direct Motor		Planetary Gear Reducer
		Servo Motor Frame	Stepper Motor Frame	
5mm	1: 1.5: 2: 1 1 1	80, 100, 130	N/A	60, 90, 115
10mm				
25mm				

3) Screw Parameters

- (Note: The load of the screw is based on Stroke ≤300mm, and the Stroke >300mm needs to consult our technicians.)

Screw Model	Screw Type	Screw Diam.	Screw Lead	Dynamic Load Ca (kN)	Static Load Coa (kN)	Stiffness Kg/μm
SFNU2505-4	Ball Screw	25mm	5mm	16.9	48	45
SFNU2510-4			10mm	28.9	71.5	50
SFA2525-1.8			25mm	8.2	21.5	22

Screw Model	Ball Diam.	Screw Shaft	Slenderness Ratio	Accuracy Grade / Positioning Accuracy
SFNU2505-4	3.175mm	22K6	1:30	C5/±0.01
SFNU2510-4	4.762mm			
SFA2525-1.8	3.175mm			

4) Bearing Parameters

Bearing Model	Dynamic Load Cr (kN)	Static Load Cor (kN)
Deep Groove Ball Bearing 6206-ZZx2	19.5	11.3
Thrust Ball Bearing 51206	29.3	58

Specifications and Dimensions
5) Synchronous Wheel and Timing Belt Parameters

Ratio	Synchronous Wheels				Timing Belt		
	Drive Wheels		Driven Wheels		Center Distance	Circumference	Width
	Model	Number of Teeth	Model	Number of Teeth			
1:1		40		40	110mm	420	25mm
1.5:1	5M25T42	30	5M25T42	45		410	
2:1		30		60		450	

6) Front Attachment Dimensions

Front Attachment	ΦA	ΦB	ΦC	C	D	E	F	H	G	M
Male Threaded end	Φ65	Φ50	—	40	65	3	12	—	46	M30x1.5
Female Threaded end	Φ65	Φ50	—	40	25	3	—	—	46	M20
Clevis end	Φ65	Φ50	Φ30	—	150	3	30	51	46	—
Rod end	Φ65	Φ50	Φ25	—	80	3	31	—	46	—
Fork end	Φ65	Φ50	Φ30	—	150	3	35	73	70	—

Specifications and Dimensions

KMZ80

• Note: When different motors are matched, the dimensions may change.

(P01) Front Flange: ≤400mm:L1 = Stroke + 120mm, L2 = Stroke + 273mm
 >400mm:L1 = Stroke + 150mm, L2 = Stroke + 303mm

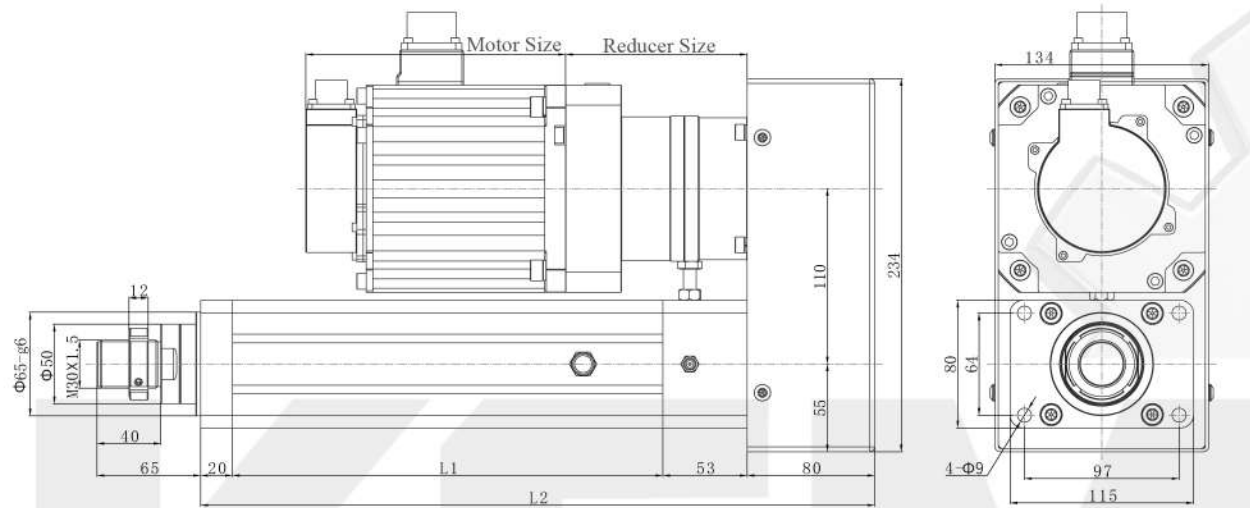

(P02) Rear Flange: ≤400mm:L1 = Stroke + 120mm, L2 = Stroke + 283mm
 >400mm:L1 = Stroke + 150mm, L2 = Stroke + 313mm

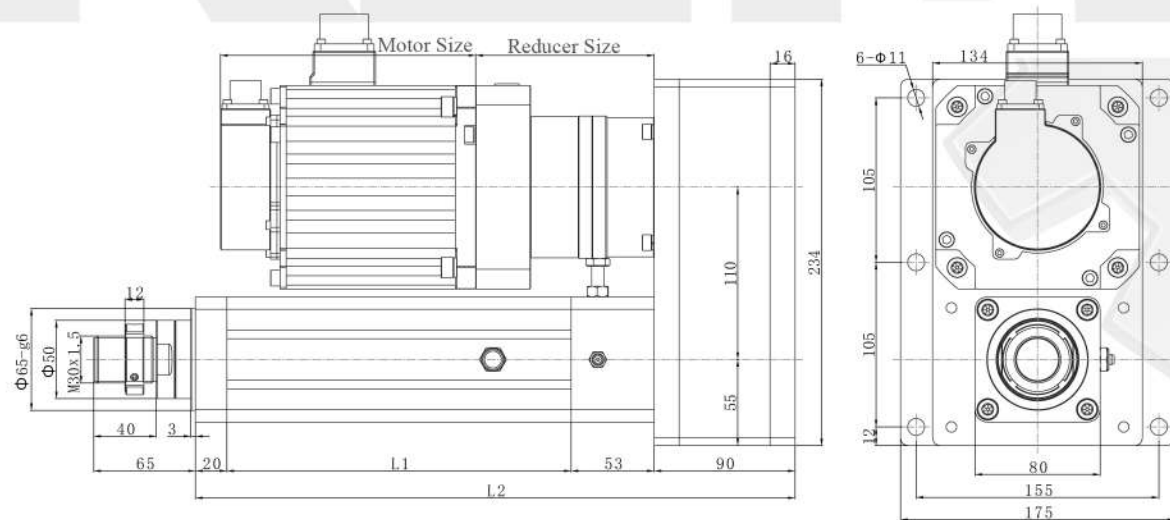

*. Dimensions are subject to change without notice



Specifications and Dimensions

KMZ80

• Note: When different motors are matched, the dimensions may change.

(P03) Trunnion: ≤400mm:L1 = Stroke + 120mm, L2 = Stroke + 273mm
 >400mm:L1 = Stroke + 150mm, L2 = Stroke + 303mm

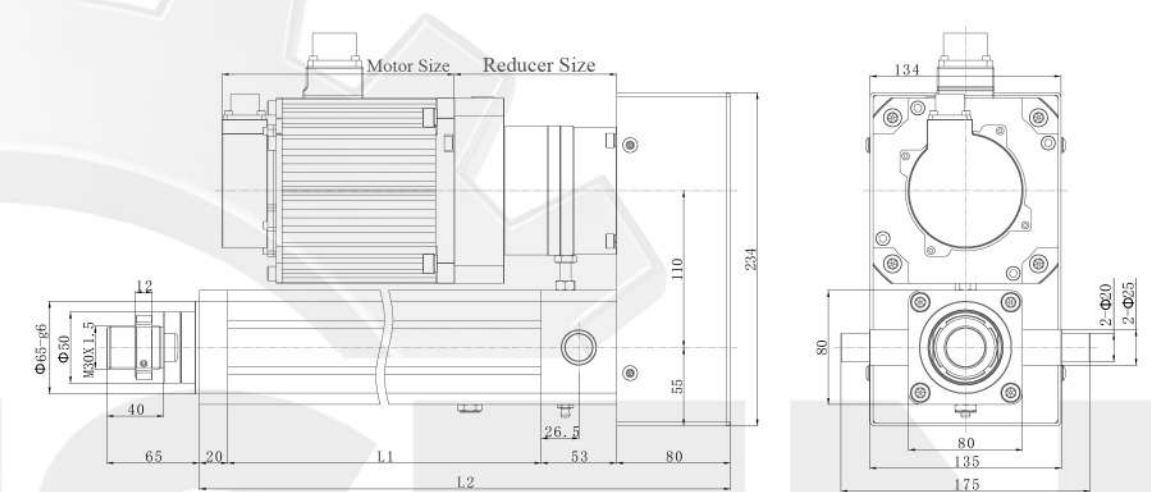

(P04) Side Flange: ≤400mm:L1 = Stroke + 120mm, L2 = Stroke + 273mm
 >400mm:L1 = Stroke + 150mm, L2 = Stroke + 303mm

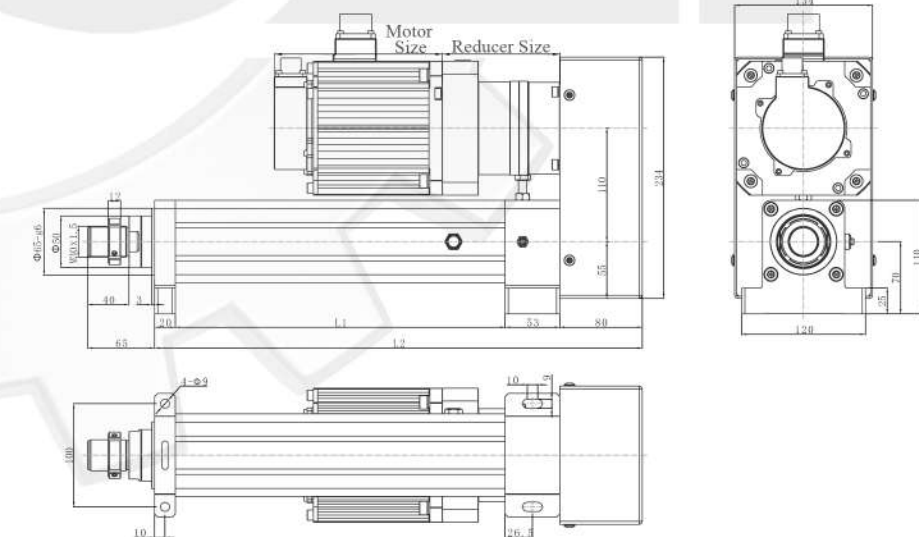

*. Dimensions are subject to change without notice



Specifications and Dimensions

KMZ80

• Note: When different motors are matched, the dimensions may change.

(P05) Rear Hinge: ≤400mm:L1 = Stroke + 120mm, L2 = Stroke + 443mm
 >400mm:L1 = Stroke + 150mm, L2 = Stroke + 473mm

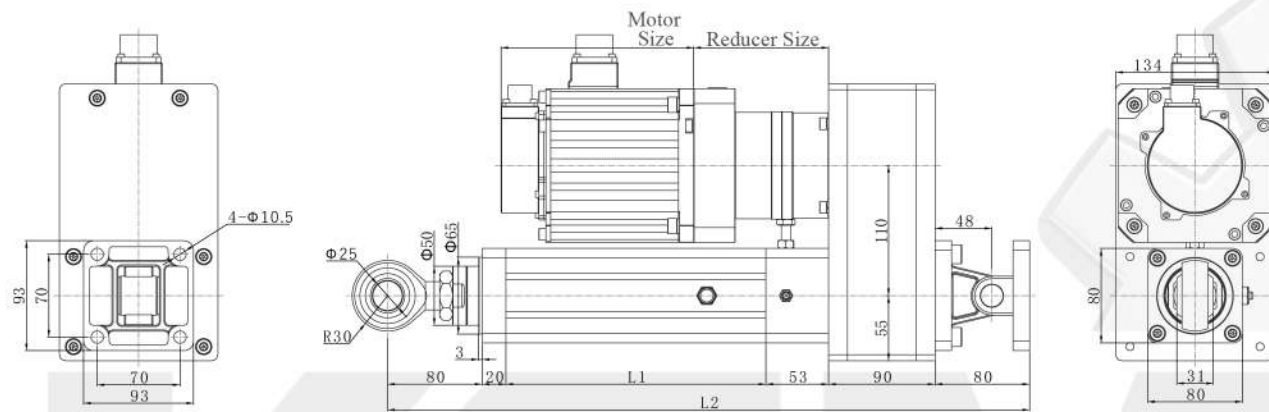

(P06) Guide Column Type: L1 = Stroke + 120mm, L2 = Stroke + 342mm

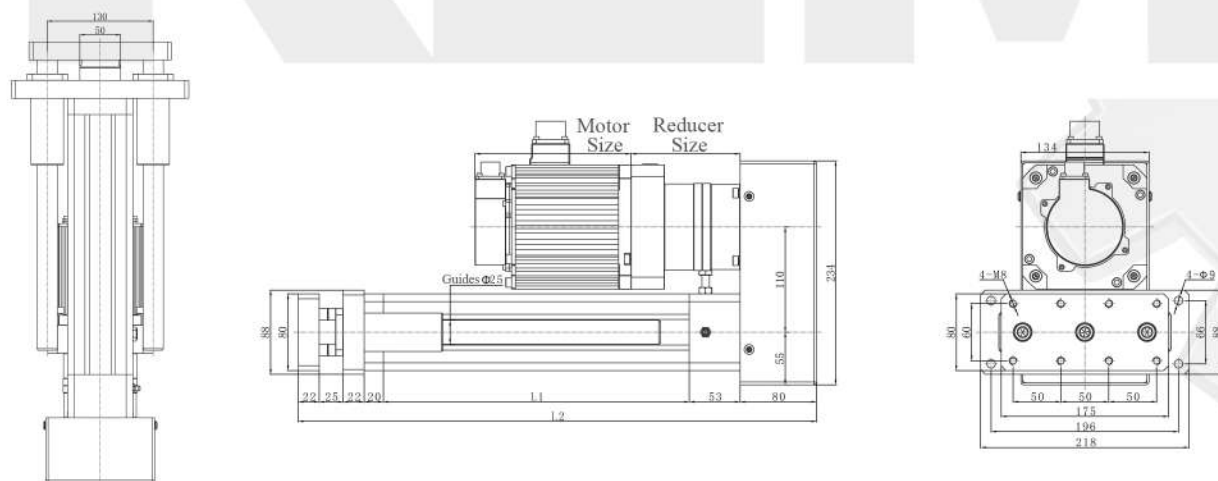

*. Dimensions are subject to change without notice



Specifications and Dimensions

KMZ80

• Note: When different motors are matched, the dimensions may change.

(P07) Front Lock Type: ≤400mm:L1 = Stroke + 120mm, L2 = Stroke + 283mm
 >400mm:L1 = Stroke + 150mm, L2 = Stroke + 313mm

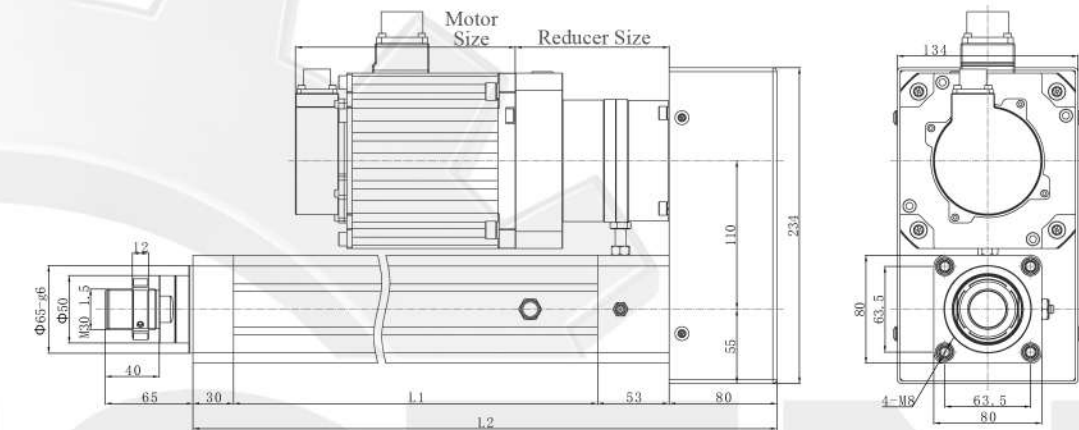

*. Dimensions are subject to change without notice



Specifications and Dimensions
KMZ94 Parameters for Standard Configurations
1) Basic Parameters

- (Note: The Push Load, Stroke and Speed of the Servo Electric Cylinders need to be combined with the actual use, and the three upper limits cannot be used in combination at the same time.) all size, easy installation and use, simple maintenance, low noise, long life, multiple safety protection measures.

Cylinder O.D. (mm)	Cylinder I.D. (mm)	Maximum Push Load	Stroke	Maximum Speed	Rotation Degree of Piston Rod	Limit Switches
94x94 mm	Φ80 mm	≤30KN	≤960 mm	≤1000 mm/s	±0.3°	Magnetic Switches

2) Optional

Screw Lead	Ratio	Direct Motor		Planetary Gear Reducer
		Servo Motor Frame	Stepper Motor Frame	
5mm				
10mm	1: 1.5: 2:	80, 100, 130	N/A	N/A
20mm	1 1 1			
32mm				

3) Screw Parameters

- (Note: The load of the screw is based on Stroke ≤300mm, and the Stroke >300mm needs to consult our technicians.)

Screw Model	Screw Type	Screw Diam.	Screw Lead	Dynamic Load Ca (kN)	Static Load Coa (kN)	Stiffness Kgf/μm
SFNU3205-4	Ball Screw	32mm	5mm	18.8	62.2	54
SFNU3210-4			10mm	47.1	119.7	61
SFA3220-2.8			20mm	18.7	53.7	43
SFA3232-1.8			32mm	12.3	33.5	27

Screw Model	Ball Diam.	Screw Shaft	Slenderness Ratio	Accuracy Grade / Positioning Accuracy	
SFNU3205-4	3.175mm	22K6	1:30	C5/±0.01	C7/±0.02
SFNU3210-4	6.35mm				
SFA3220-2.8	3.969mm				
SFA3232-1.8	3.969mm				

4) Bearing Parameters

Bearing Model	Dynamic Load Cr (kN)	Static Load Cor (kN)
Tapered Roller Bearing 31305x2	38	40

Specifications and Dimensions
5) Synchronous Wheel and Timing Belt Parameters

Ratio	Synchronous Wheels				Timing Belt		
	Drive Wheels		Driven Wheels		Center Distance	Circumference	Width
	Model	Number of Teeth	Model	Number of Teeth			
1:1		30		30	116mm	472	30mm
1.5:1	8M30T48	20	8M30T38	30		432	
2:1		20		40		480	

6) Front Attachment Dimensions

Front Attachment	ΦA	ΦB	ΦC	C	D	E	F	H	G	M
Male Threaded end	Φ80	Φ60	—	50	80	3	14	—	55	M40x1.5
Female Threaded end	Φ80	Φ60	—	40	30	3	—	—	55	M24
Clevis end	Φ80	Φ60	Φ35	—	195	3	35	55	55	—
Rod end	Φ80	Φ60	Φ30	—	94	3	37	—	55	—
Fork end	Φ80	Φ60	Φ35	—	195	3	35	73	70	—

Specifications and Dimensions

KMZ94

• Note: When different motors are matched, the dimensions may change.

(P01) Front Flange: L1 = Stroke + 130mm, L2 = Stroke + 278mm

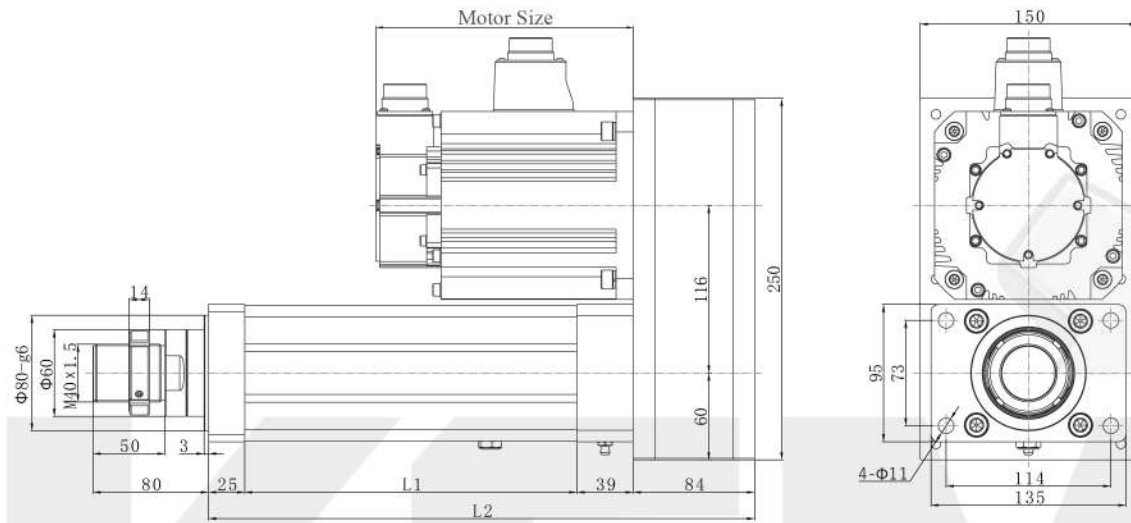

(P02) Rear Flange: L1 = Stroke + 130mm, L2 = Stroke + 278mm

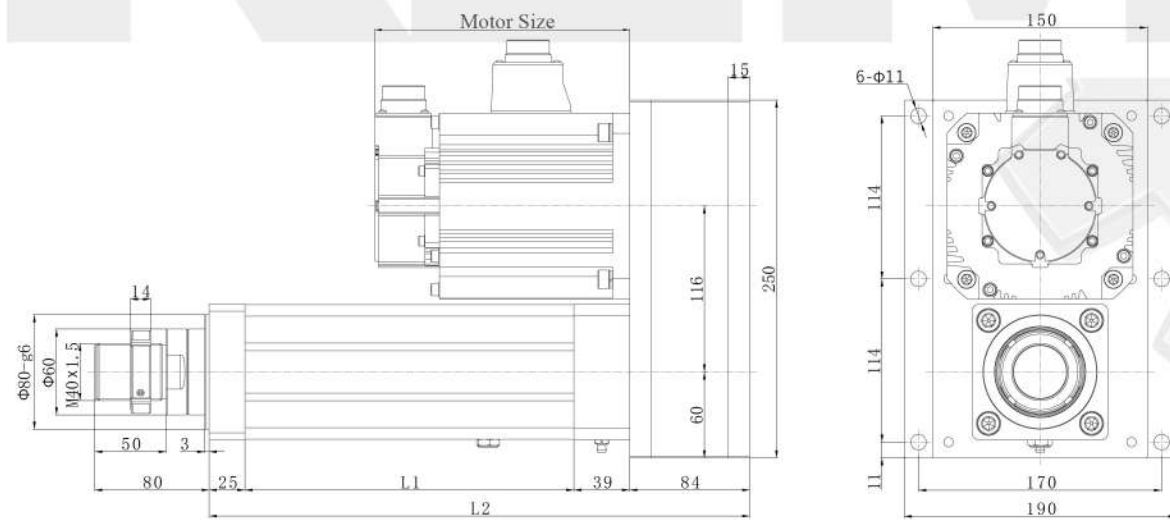

*. Dimensions are subject to change without notice



Specifications and Dimensions

KMZ94

• Note: When different motors are matched, the dimensions may change.

(P03) Trunnion: L1 = Stroke + 130mm, L2 = Stroke + 278mm

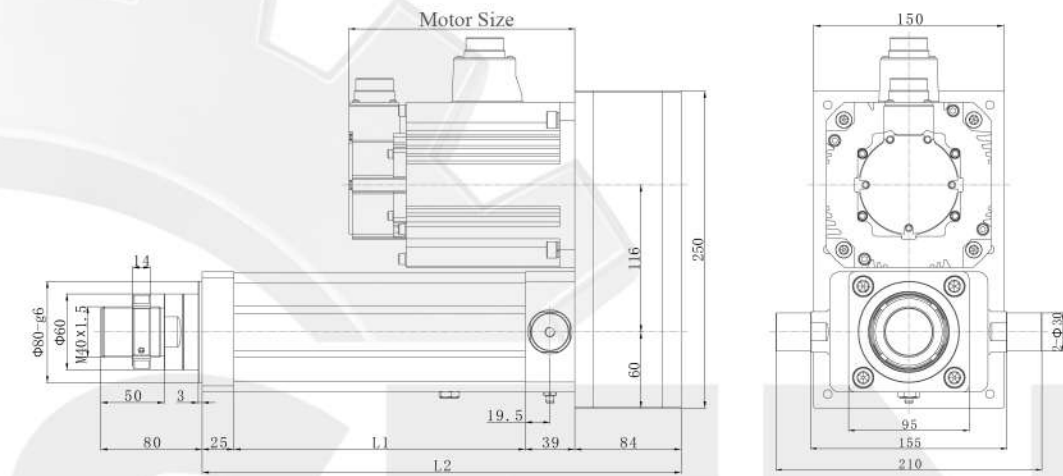

(P04) Side Flange: L1 = Stroke + 130mm, L2 = Stroke + 278mm

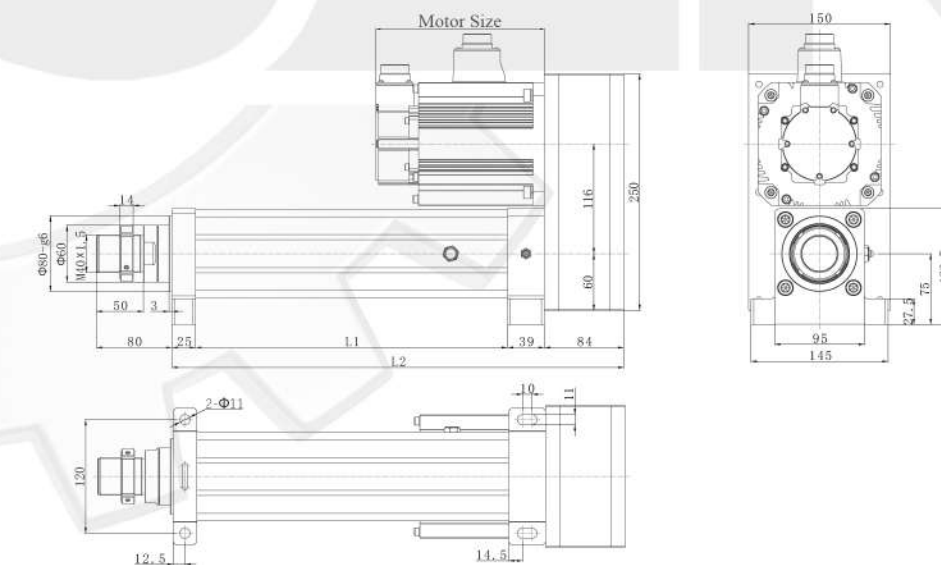

*. Dimensions are subject to change without notice



Specifications and Dimensions

KMZ94

• Note: When different motors are matched, the dimensions may change.

(P05) Rear Hinge: L1 = Stroke + 130mm, L2 = Stroke + 452mm

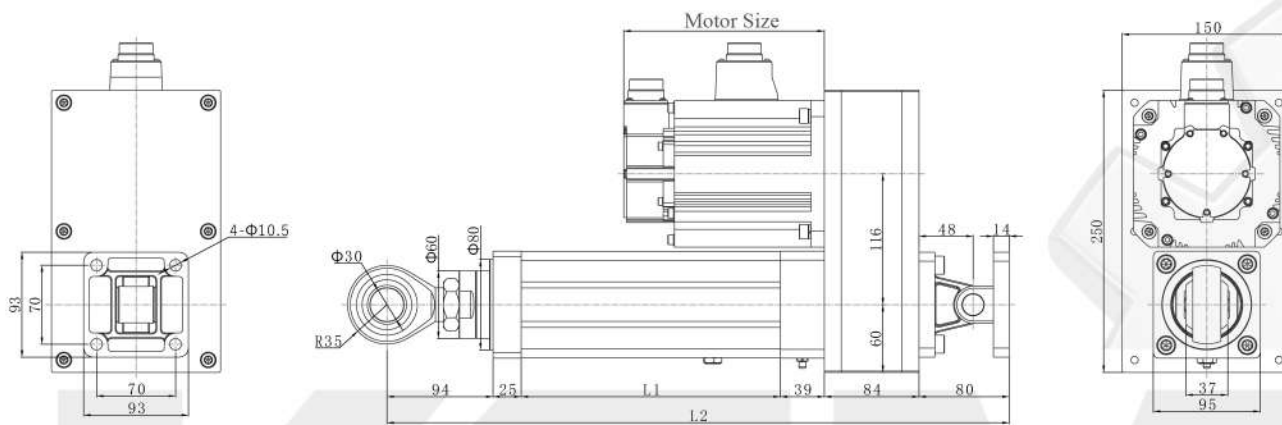

(P06) Guide Column Type: L1 = Stroke + 130mm, L2 = Stroke + 364mm

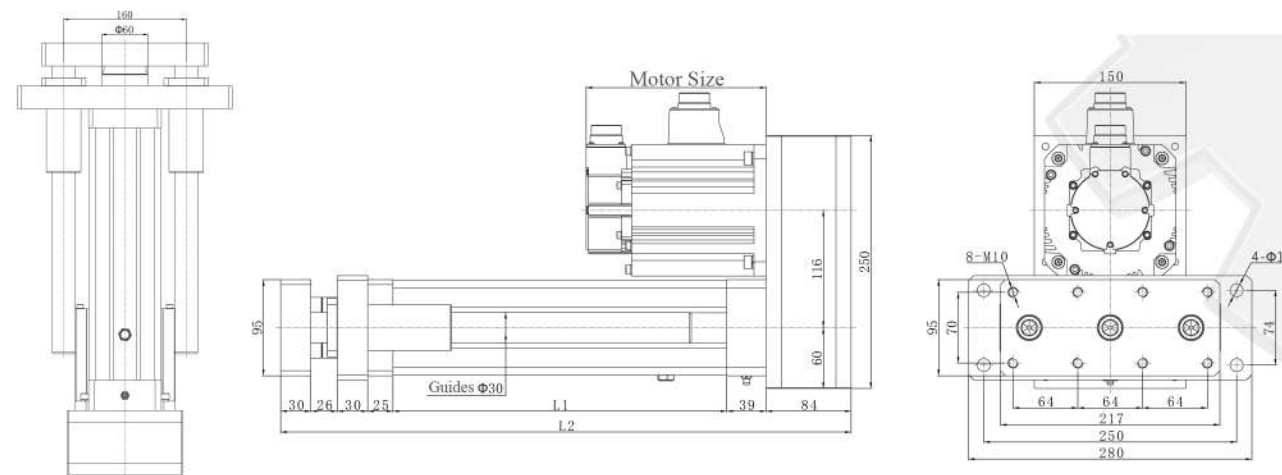

*. Dimensions are subject to change without notice



Specifications and Dimensions

KMZ94

• Note: When different motors are matched, the dimensions may change.

(P07) Front Lock Type: L1 = Stroke + 130mm, L2 = Stroke + 286mm

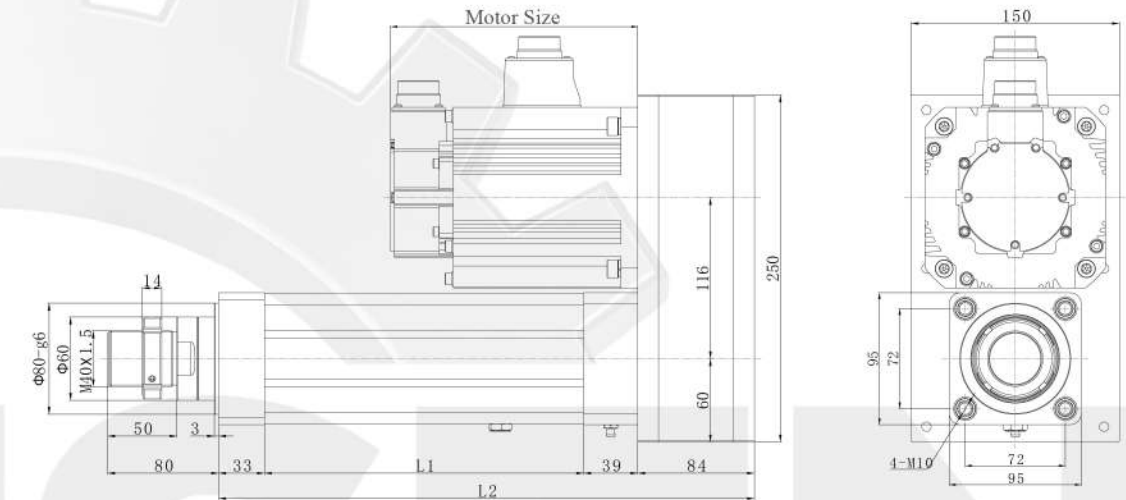

*. Dimensions are subject to change without notice



Specifications and Dimensions
KMZ94Z Parameters for Standard Configurations
1) Basic Parameters

- (Note: The Push Load, Stroke and Speed of the Servo Electric Cylinders need to be combined with the actual use, and the three upper limits cannot be used in combination at the same time.) all size, easy installation and use, simple maintenance, low noise, long life, multiple safety protection measures.

Cylinder O.D. (mm)	Cylinder I.D. (mm)	Maximum Push Load	Stroke	Maximum Speed	Rotation Degree of Piston Rod	Limit Switches
94x94 mm	Φ80 mm	≤30KN	≤960 mm	≤1000 mm/s	±0.3°	Magnetic Switches

2) Optional

Screw Lead	Ratio	Direct Motor		Planetary Gear Reducer
		Servo Motor Frame	Stepper Motor Frame	
5mm				
10mm	1: 1.5: 2:			
20mm	1 1 1	180	N/A	85, 90, 115
32mm				

3) Screw Parameters

- (Note: The load of the screw is based on Stroke ≤300mm, and the Stroke >300mm needs to consult our technicians.)

Screw Model	Screw Type	Screw Diam.	Screw Lead	Dynamic Load Ca (kN)	Static Load Coa (kN)	Stiffness Kgf/μm
SFNU3205-4	Ball Screw	32mm	5mm	18.8	62.2	54
SFNU3210-4			10mm	47.1	119.7	61
SFA3220-2.8			20mm	18.7	53.7	43
SFA3232-1.8			32mm	12.3	33.5	27

Screw Model	Ball Diam.	Screw Shaft	Slenderness Ratio	Accuracy Grade / Positioning Accuracy
SFNU3205-4	3.175mm	32K10	1:30	C5/±0.01
SFNU3210-4	6.35mm			
SFA3220-2.8	3.969mm			
SFA3232-1.8	3.969mm			

4) Bearing Parameters

Bearing Model	Dynamic Load Cr (kN)	Static Load Cor (kN)
Deep Groove Ball Bearing 6007-ZZx2	15.9	10.3
Thrust Ball Bearing 51207	39	78

Specifications and Dimensions
5) Synchronous Wheel and Timing Belt Parameters

Ratio	Synchronous Wheels				Timing Belt	
	Drive Wheels		Driven Wheels		Center Distance	Circumference
	Model	Number of Teeth	Model	Number of Teeth		Width
1:1		45		45	155mm	672
1.5:1	8M30T47	30	8M30T47	45		608
2:1		30		60		680

6) Front Attachment Dimensions

Front Attachment	ΦA	ΦB	ΦC	C	D	E	F	H	G	M
Male Threaded end	Φ80	Φ60	—	50	80	3	14	—	55	M40x1.5
Female Threaded end	Φ80	Φ60	—	40	30	3	—	—	55	M24
Clevis end	Φ80	Φ60	Φ35		195	3	35	55	55	—
Rod end	Φ80	Φ60	Φ30		94	3	37	—	55	—
Fork end	Φ80	Φ60	Φ35		195	3	35	73	70	—

Specifications and Dimensions

KMZ94Z

• Note: When different motors are matched, the dimensions may change.

(P01) Front Flange: L1 = Stroke + 130mm, L2 = Stroke + 313mm

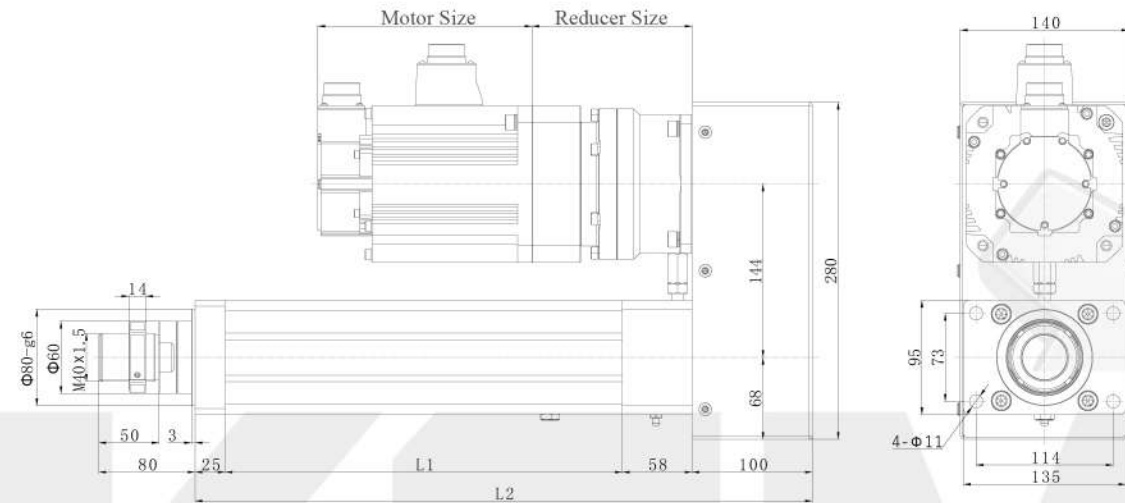

(P02) Rear Flange: L1 = Stroke + 130mm, L2 = Stroke + 313mm

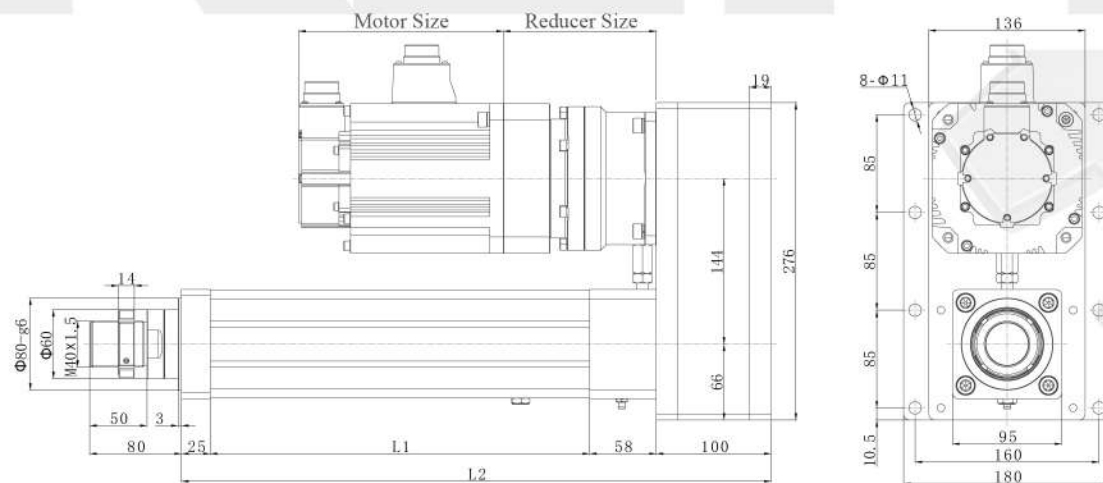

*. Dimensions are subject to change without notice



Specifications and Dimensions

KMZ94Z

• Note: When different motors are matched, the dimensions may change.

(P03) Trunnion: L1 = Stroke + 130mm, L2 = Stroke + 313mm

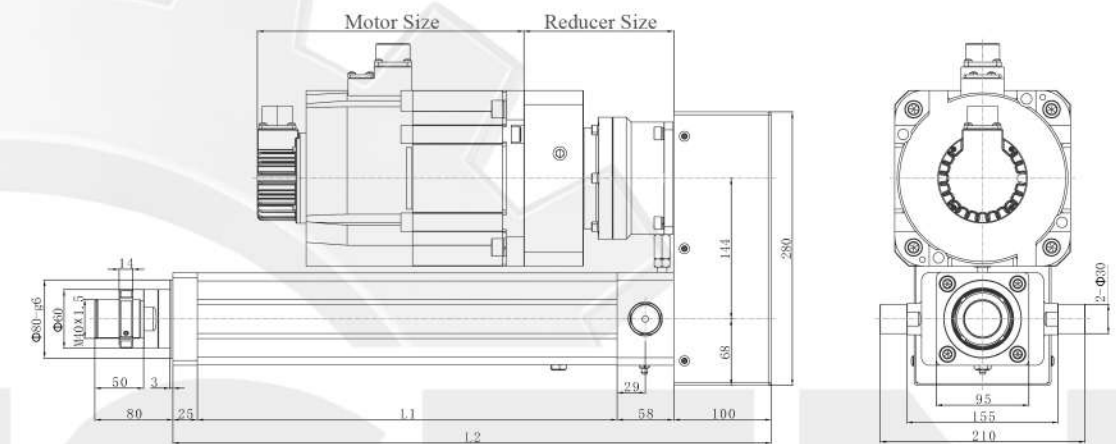

(P04) Side Flange: L1 = Stroke + 130mm, L2 = Stroke + 314mm

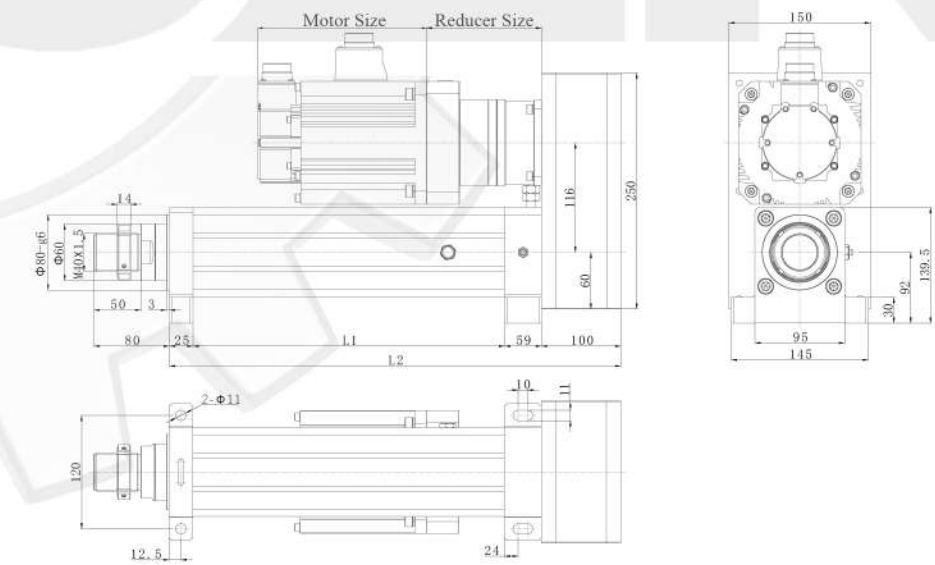

*. Dimensions are subject to change without notice



Specifications and Dimensions

KMZ94Z

• Note: When different motors are matched, the dimensions may change.

(P05) Rear Hinge: L1 = Stroke + 130mm, L2 = Stroke + 488mm

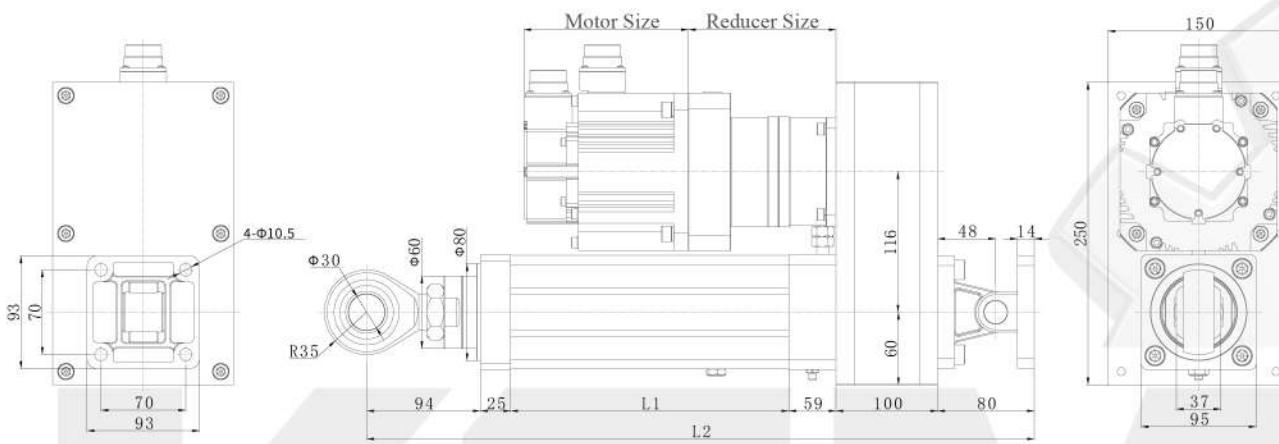

(P06) Guide Column Type: L1 = Stroke + 130mm, L2 = Stroke + 400mm

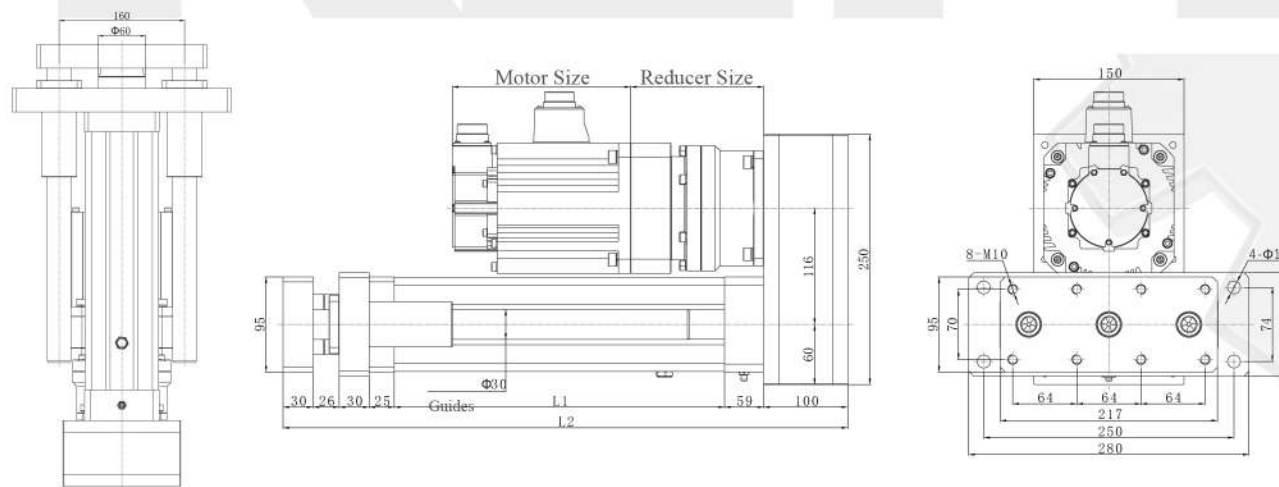

*. Dimensions are subject to change without notice



Specifications and Dimensions

KMZ94Z

• Note: When different motors are matched, the dimensions may change.

(P07) Front Lock Type: L1 = Stroke + 130mm, L2 = Stroke + 322mm

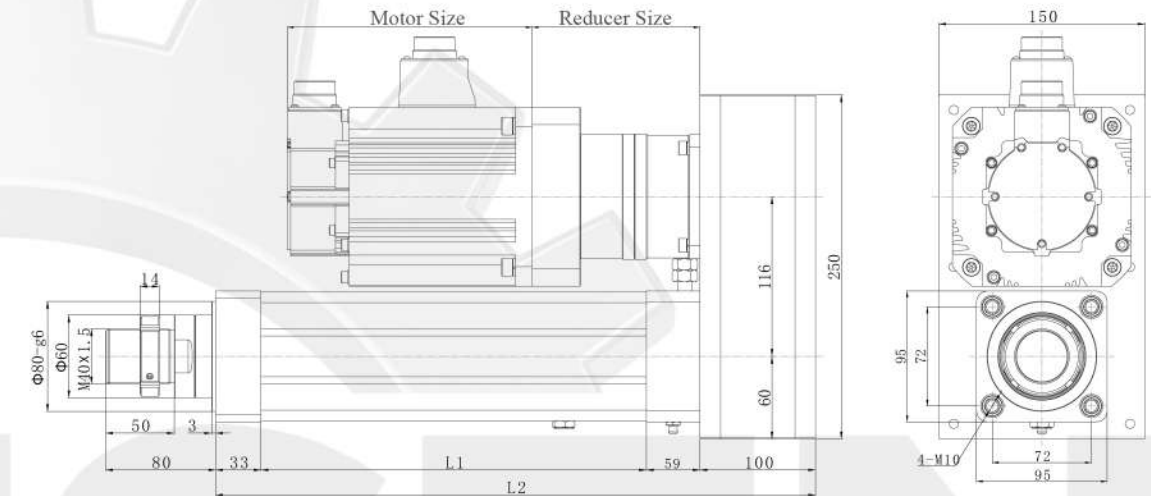

*. Dimensions are subject to change without notice



Specifications and Dimensions

KMZ115 Parameters for Standard Configurations

1) Basic Parameters

- (Note: The Push Load, Stroke and Speed of the Servo Electric Cylinders need to be combined with the actual use, and the three upper limits cannot be used in combination at the same time.) all size, easy installation and use, simple maintenance, low noise, long life, multiple safety protection measures.

Cylinder O.D. (mm)	Cylinder I.D. (mm)	Maximum Push Load	Stroke	Maximum Speed	Rotation Degree of Piston Rod	Limit Switches
112x112 mm	Φ100 mm	≤50KN	≤1200 mm	≤250 mm/s	±0.3°	Magnetic Switches

2) Optional

Screw Lead	Ratio	Direct Motor		Planetary Gear Reducer
		Servo Motor Frame	Stepper Motor Frame	
5mm	1: 1.5: 2:	130, 180	N/A	115, 142
10mm				
20mm	1 1 1			
40mm				

3) Screw Parameters

- (Note: The load of the screw is based on Stroke ≤300mm, and the Stroke >300mm needs to consult our technicians.)

Screw Model	Screw Type	Screw Diam.	Screw Lead	Dynamic Load Ca (kN)	Static Load Coa (kN)	Stiffness Kg/μm
SFNU4005-4	Ball Screw	40mm	5mm	20.6	78.3	63
SFNU4010-4			10mm	52.9	152	73
SFA4020-2.8			20mm	38.8	105	54
SFA4040-1.8			40mm	25.3	65	34
SFA4040-1.8			40mm	37	101.4	52

Screw Model	Ball Diam.	Screw Shaft	Slenderness Ratio	Accuracy Grade / Positioning Accuracy
SFNU4005-4	3.175mm	35K10	1:50	C5/±0.01
SFNU4010-4	6.35mm			
SFA4020-2.8				
SFA4040-1.8				
SFA4040-1.8				

4) Bearing Parameters

Bearing Model	Dynamic Load Cr (kN)	Static Load Cor (kN)
Angular Contact Ball Bearings 7009C/DT	24.4	19.3
Thrust Ball Bearing 51309	80	163

Specifications and Dimensions

5) Synchronous Wheel and Timing Belt Parameters

Ratio	Synchronous Wheels				Timing Belt		
	Drive Wheels		Driven Wheels		Center Distance	Circumference	Width
Model	Number of Teeth	Model	Number of Teeth				
1:1		40		40	176mm	672	50mm
1.5:1	8M50T59	30	8M50T59	45		656	
2:1		30		60		720	

6) Front Attachment Dimensions

Front Attachment	ΦA	ΦB	ΦC	C	D	E	F	H	G	M
Male Threaded end	Φ90	Φ75	—	60	110	5	14	—	—	M40x1.5
Female Threaded end	Φ90	Φ75	—	40	30	5	—	—	—	M24
Clevis end	Φ90	Φ75	Φ35	—	215	5	35	55	—	—
Rod end	Φ90	Φ75	Φ35	—	140	5	25	—	—	—
Fork end	Φ90	Φ75	Φ35	—	215	5	35	73	70	—

KMZ115 Dimensions

- Note: When different motors are matched, the dimensions may change.

(P01) Front Flange: L1 = Stroke + 150mm, L2 = Stroke + 374mm

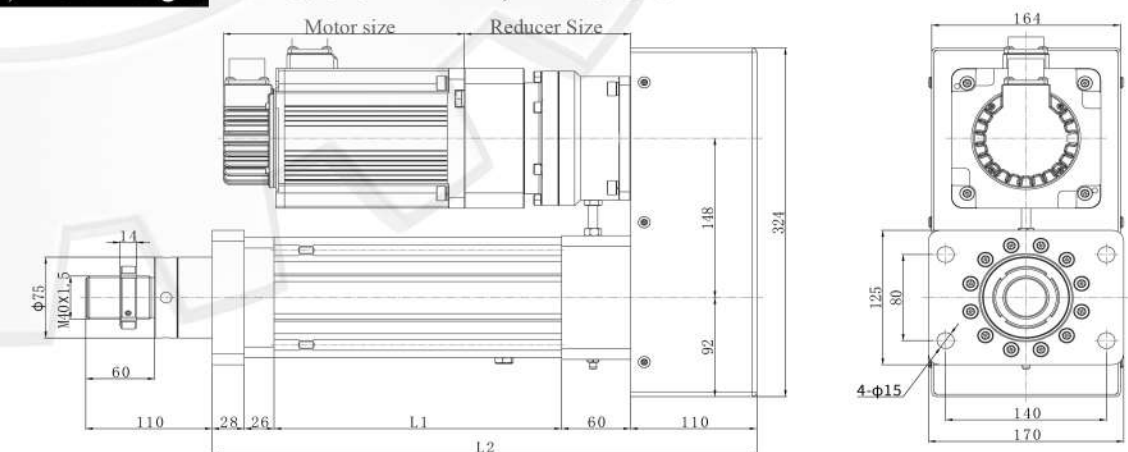

*. Dimensions are subject to change without notice

Specifications and Dimensions

KMZ135 Parameters for Standard Configurations

1) Basic Parameters

- (Note: The Push Load, Stroke and Speed of the Servo Electric Cylinders need to be combined with the actual use, and the three upper limits cannot be used in combination at the same time.) all size, easy installation and use, simple maintenance, low noise, long life, multiple safety protection measures.

Cylinder O.D. (mm)	Cylinder I.D. (mm)	Maximum Push Load	Stroke	Maximum Speed	Rotation Degree of Piston Rod	Limit Switches	
134x134mm	Φ120mm	≤100KN	≤1500mm	≤250mm/s	±0.3°	Magnetic Switches	Proximity Switches

2) Optional

Screw Lead	Ratio	Direct Motor		Planetary Gear Reducer
		Servo Motor Frame	Stepper Motor Frame	
10mm	1: 1.5: 2:	130, 180	N/A	115, 142
20mm	1 1 1			

3) Screw Parameters

- (Note: The load of the screw is based on Stroke ≤300mm, and the Stroke >300mm needs to consult our technicians.)

Screw Model	Screw Type	Screw Diam.	Screw Lead	Dynamic Load Ca (kN)	Static Load Coa (kN)	Stiffness Kg/μm
JFZ5010-8	Ball Screw	50mm	10mm	104.1	251.2	—
SFS5020-3.8			20mm	13.7	130.7	66

Screw Model	Ball Diam.	Screw Shaft	Slenderness Ratio	Accuracy Grade / Positioning Accuracy	
JFZ5010-8	7.144mm	40K12	1:50	C5/±0.01	C7/±0.02
SFS5020-3.8	6.35mm				

4) Bearing Parameters

Bearing Model	Dynamic Load Cr (kN)	Static Load Cor (kN)
Deep Groove Ball Bearing 6211x2	43.4	29.2
Thrust Ball Bearing 51311	119	246

Specifications and Dimensions

5) Synchronous Wheel and Timing Belt Parameters

Ratio	Synchronous Wheels				Center Distance	Timing Belt	
	Drive Wheels		Driven Wheels			Circumference	Width
	Model	Number of Teeth	Model	Number of Teeth			
1:1		28		28	196mm	784	50mm
1.5:1	14M50T72	24	14M50T62	36		812	
2:1		18		36		784	

6) Front Attachment Dimensions

Front Attachment	ΦA	ΦB	ΦC	C	D	E	F	H	G	M
Male Threaded end	Φ110	Φ90	—	70	120	10	14	—	—	M50x2
Female Threaded end	Φ110	Φ90	—	45	50	10	—	—	—	M30x1.5
Clevis end	Φ110	Φ90	Φ40	—	245	10	40	85	—	—
Rod end	Φ110	Φ90	Φ50	—	165	10	60	—	—	—
Fork end	Φ110	Φ90	Φ40	—	245	10	40.3	86	85	—

KMZ135 Dimensions

- Note: When different motors are matched, the dimensions may change.

(P01) Front Flange: L1 = Stroke + 200mm, L2 = Stroke + 480mm

* Magnetic Switches or Proximity Switches

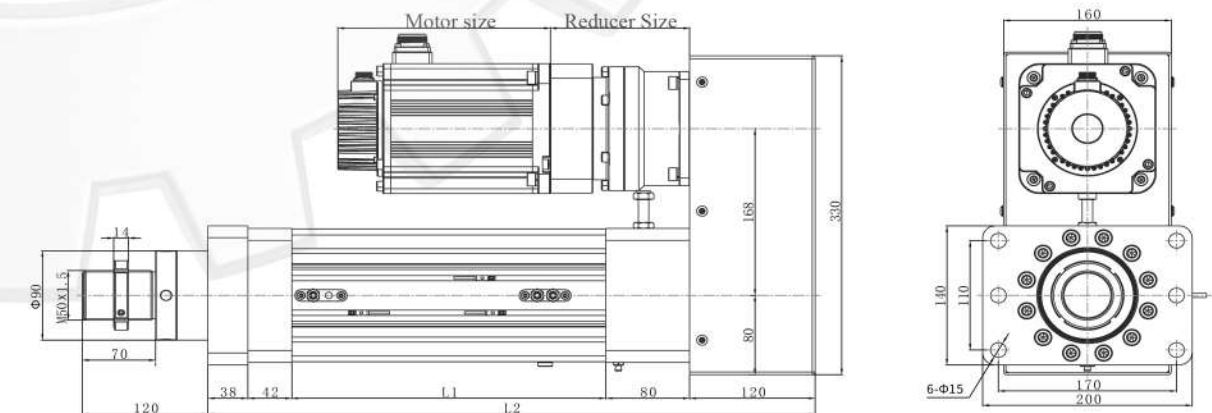

*. Dimensions are subject to change without notice

Specifications and Dimensions

KMZ140 Parameters for Standard Configurations

1) Basic Parameters

- (Note: The Push Load, Stroke and Speed of the Servo Electric Cylinders need to be combined with the actual use, and the three upper limits cannot be used in combination at the same time.) all size, easy installation and use, simple maintenance, low noise, long life, multiple safety protection measures.

Cylinder O.D. (mm)	Cylinder I.D. (mm)	Maximum Push Load	Stroke	Maximum Speed	Rotation Degree of Piston Rod	Limit Switches
Φ132mm	Φ110mm	≤130KN	≤1500mm	≤250mm/s	±0.3°	Proximity Switches

2) Optional

Screw Lead	Ratio	Direct Motor		Planetary Gear Reducer
		Servo Motor Frame	Stepper Motor Frame	
10mm	1:	—	—	142
20mm	1	—	—	

3) Screw Parameters

- (Note: The load of the screw is based on Stroke ≤300mm, and the Stroke >300mm needs to consult our technicians.)

Screw Model	Screw Type	Screw Diam.	Screw Lead	Dynamic Load Ca (kN)	Static Load Coa (kN)	Stiffness Kg/μm
JFZ5010-8	Ball Screw	50mm	10mm	104.1	251.2	—
SFU5010-8				104.1	251.2	—
JFZ5020-7			20mm	95.5	230.7	—

Screw Model	Ball Diam.	Screw Shaft	Slenderness Ratio	Accuracy Grade / Positioning Accuracy	
JFZ5010-8	7.144mm	40K12	1:50	C5/±0.01	C7/±0.02
SFU5010-8					
JFZ5020-7					

4) Bearing Parameters

Bearing Model	Dynamic Load Cr (kN)	Static Load Cor (kN)
Deep Groove Ball Bearing 6009-ZZx2	19.9	14
Thrust Ball Bearing 51212	73.5	179

Specifications and Dimensions

5) Synchronous Wheel and Timing Belt Parameters

Ratio	Synchronous Wheels				Timing Belt		
	Drive Wheels		Driven Wheels		Center Distance	Circumference	Width
1:1	Model	Number of Teeth	Model	Number of Teeth	196mm	784	50mm
	14M65T77	28	14M65T77	28			

6) Front Attachment Dimensions

Front Attachment	ΦA	ΦB	ΦC	C	D	E	F	H	G	M
Male Threaded end	Φ110	Φ90	—	70	120	10	14	—	—	M50x2
Female Threaded end	Φ110	Φ90	—	45	50	10	—	—	—	M30x1.5
Clevis end	Φ110	Φ90	Φ40	—	245	10	40	85	—	—
Rod end	Φ110	Φ90	Φ50	—	165	10	60	—	—	—
Fork end	Φ110	Φ90	Φ40	—	245	10	40.3	86	85	—

KMZ140 Dimensions

- Note: When different motors are matched, the dimensions may change.
- (P01) Front Flange: L1 = Stroke + 275mm, L2 = Stroke + 495mm

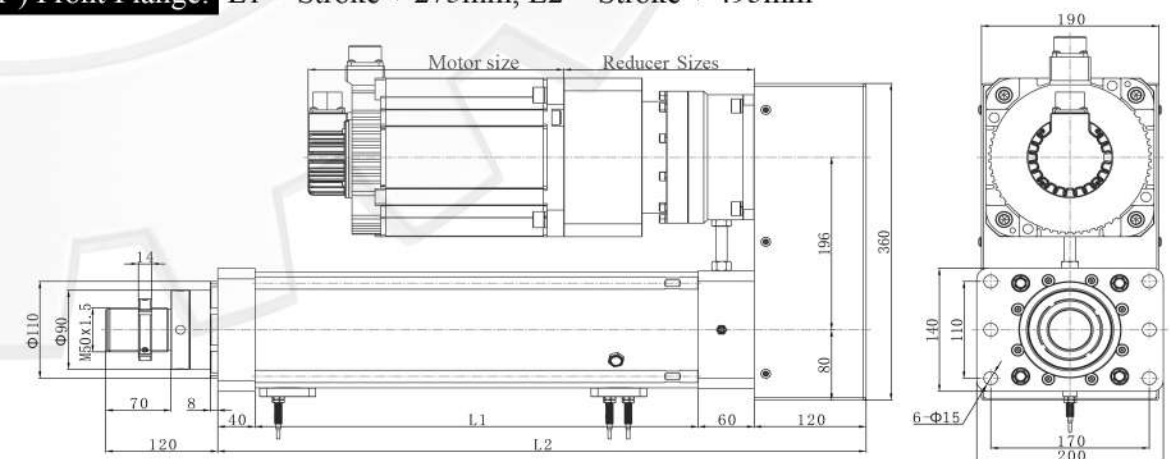

*. Dimensions are subject to change without notice

Specifications and Dimensions

KMZ160 Parameters for Standard Configurations

1) Basic Parameters

- (Note: The Push Load, Stroke and Speed of the Servo Electric Cylinders need to be combined with the actual use, and the three upper limits cannot be used in combination at the same time.) all size, easy installation and use, simple maintenance, low noise, long life, multiple safety protection measures.

Cylinder O.D. (mm)	Cylinder I.D. (mm)	Maximum Push Load	Stroke	Maximum Speed	Rotation Degree of Piston Rod	Limit Switches
158x158mm	Φ140mm	≤180KN	≤1800mm	≤250mm/s	±0.3°	Proximity Switches

2) Optional

Screw Lead	Ratio	Direct Motor		Planetary Gear Reducer
		Servo Motor Frame	Stepper Motor Frame	
20mm	1:1	—	—	142, 180

3) Screw Parameters

- (Note: The load of the screw is based on Stroke ≤300mm, and the Stroke >300mm needs to consult our technicians.)

Screw Model	Screw Type	Screw Diam.	Screw Lead	Dynamic Load Ca (kN)	Static Load Coa (kN)	Stiffness Kgf/μm
JFZ6320-8	Ball Screw	63mm	20mm	326.2	774.7	—

Screw Model	Ball Diam.	Screw Shaft	Slenderness Ratio	Accuracy Grade / Positioning Accuracy
JFZ6320-8	12.7mm	50K14	1:50	C5/±0.01 C7/±0.02

4) Bearing Parameters

Bearing Model	Dynamic Load Cr (kN)	Static Load Cor (kN)
Angular Contact Ball Bearings 7212C/DT	61	48.3
Thrust Spherical Roller Bearings 29412	335	900

Specifications and Dimensions

5) Synchronous Wheel and Timing Belt Parameters

Ratio	Synchronous Wheels				Timing Belt		
	Drive Wheels		Driven Wheels		Center Distance	Circumference	Width
	Model	Number of Teeth	Model	Number of Teeth			
1:1	14M65T86.5	36	14M65T76.5	36	210mm	924	65mm

6) Front Attachment Dimensions

• Clevis end		• Fork end								
• Male Threaded end		• Female Threaded end		• Rod end						
Front Attachment	ΦA	ΦB	ΦC	C	D	E	F	H	G	M
Male Threaded end	—	Φ100	—	80	120	—	16	—	—	M60x2

KMZ160 Dimensions

- Note: When different motors are matched, the dimensions may change.

(P01) Front Flange: L1 = Stroke + 300mm, L2 = Stroke + 616mm

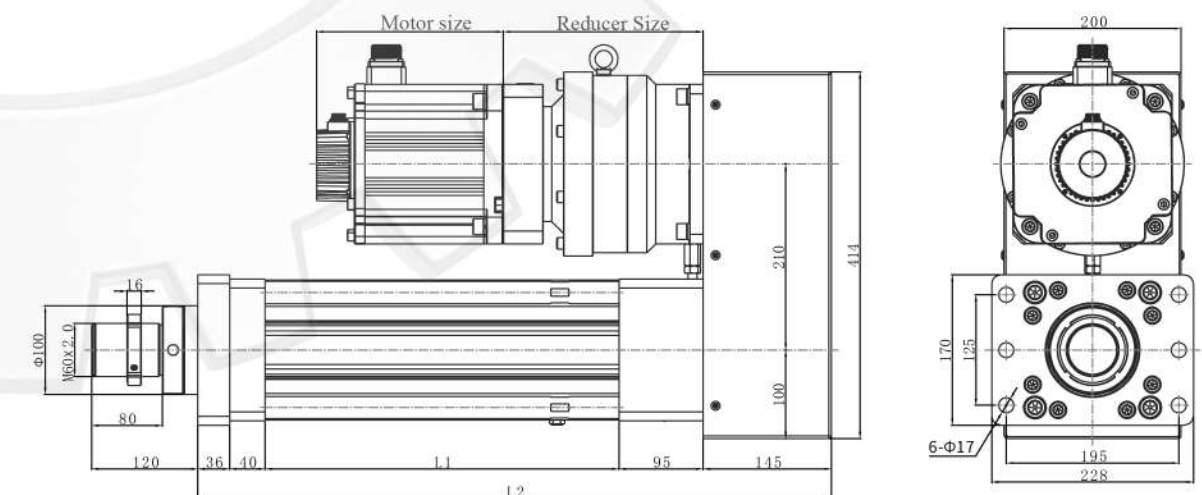

*. Dimensions are subject to change without notice

Specifications and Dimensions

KMZ180 Parameters for Standard Configurations

1) Basic Parameters

- (Note: The Push Load, Stroke and Speed of the Servo Electric Cylinders need to be combined with the actual use, and the three upper limits cannot be used in combination at the same time.) all size, easy installation and use, simple maintenance, low noise, long life, multiple safety protection measures.

Cylinder O.D. (mm)	Cylinder I.D. (mm)	Maximum Push Load	Stroke	Maximum Speed	Rotation Degree of Piston Rod	Limit Switches
180x180mm	Φ160mm	≤200KN	≤1800mm	≤250mm/s	±0.3°	Proximity Switches

2) Optional

Screw Lead	Ratio	Direct Motor		Planetary Gear Reducer
		Servo Motor Frame	Stepper Motor Frame	
20mm	1:1	—	—	142, 180

3) Screw Parameters

- (Note: The load of the screw is based on Stroke ≤300mm, and the Stroke >300mm needs to consult our technicians.)

Screw Model	Screw Type	Screw Diam.	Screw Lead	Dynamic Load Ca (kN)	Static Load Coa (kN)	Stiffness Kg/μm
G6320-8	Ball Screw	63mm	20mm	224	663	—

Screw Model	Ball Diam.	Screw Shaft	Slenderness Ratio	Accuracy Grade / Positioning Accuracy
G6320-8	12.7mm	50K14	1:50	C5/±0.01 C7/±0.02

4) Bearing Parameters

Bearing Model	Dynamic Load Cr (kN)	Static Load Cor (kN)
Tapered Roller Bearings HR 32312 Jx2	233	295

Specifications and Dimensions

5) Synchronous Wheel and Timing Belt Parameters

Ratio	Synchronous Wheels				Timing Belt		
	Drive Wheels		Driven Wheels		Center Distance	Circumference	Width
	Model	Number of Teeth	Model	Number of Teeth			
1:1	14M65T86.5	36	14M65T76.5	36	231mm	966	65mm

6) Front Attachment Dimensions

Front Attachment	ΦA	ΦB	ΦC	C	D	E	F	H	G	M
	Male Threaded end	Φ150	Φ120	—	80	135	10	16	—	—
Rod end	Φ150	Φ120	Φ60	—	245	10	50	—	—	—

KMZ180 Dimensions

- Note: When different motors are matched, the dimensions may change.

(P01) Front Flange: L1 = Stroke + 330mm, L2 = Stroke + 627mm

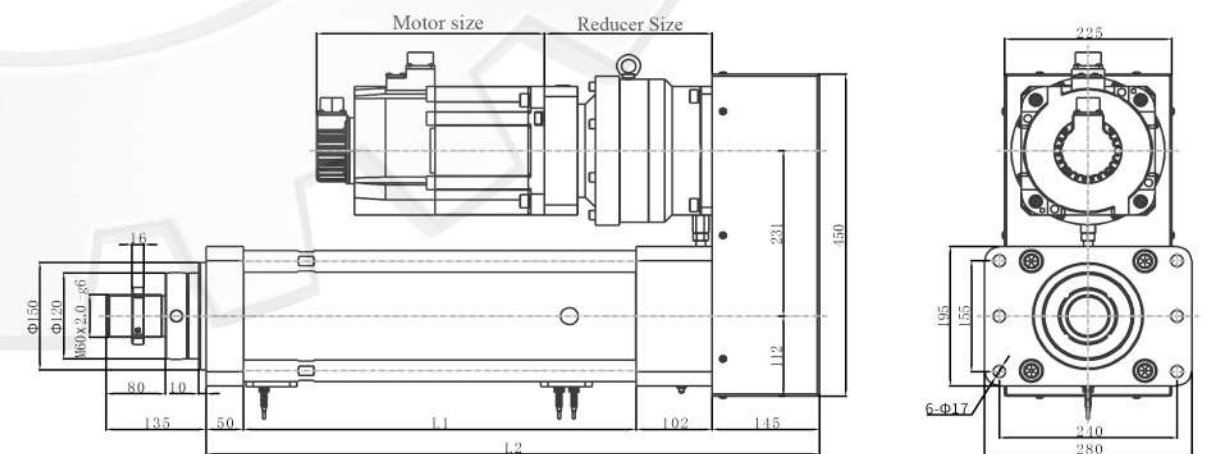

*. Dimensions are subject to change without notice

Specifications and Dimensions

KMZ245 Parameters for Standard Configurations

1) Basic Parameters

- (Note: The Push Load, Stroke and Speed of the Servo Electric Cylinders need to be combined with the actual use, and the three upper limits cannot be used in combination at the same time.) all size, easy installation and use, simple maintenance, low noise, long life, multiple safety protection measures.

Cylinder O.D. (mm)	Cylinder I.D. (mm)	Maximum Push Load	Stroke	Maximum Speed	Rotation Degree of Piston Rod	Limit Switches
Φ210mm	Φ180mm	≤400KN	≤2400mm	≤250mm/s	±0.3°	Proximity Switches

2) Optional

Screw Lead	Ratio	Direct Motor		Planetary Gear Reducer
		Servo Motor Frame	Stepper Motor Frame	
20mm	1:1	—	—	180, 220

3) Screw Parameters

- (Note: The load of the screw is based on Stroke ≤300mm, and the Stroke >300mm needs to consult our technicians.)

Screw Model	Screw Type	Screw Diam.	Screw Lead	Dynamic Load Ca (kN)	Static Load Coa (kN)	Stiffness Kg/μm
JF8020-8	Ball Screw	80mm	20mm	403.3	1210.7	—

Screw Model	Ball Diam.	Screw Shaft	Slenderness Ratio	Accuracy Grade / Positioning Accuracy
JF8020-8	12.7mm	70K20	1:50	C5/±0.01 C7/±0.02

4) Bearing Parameters

Bearing Model	Dynamic Load Cr (kN)	Static Load Cor (kN)
Tapered Roller Bearings NJ2215EM x 2	136	172
Thrust Spherical Roller Bearings 29415	490	1370

Specifications and Dimensions

5) Synchronous Wheel and Timing Belt Parameters

Ratio	Synchronous Wheels				Timing Belt		
	Drive Wheels		Driven Wheels		Center Distance	Circumference	Width
	Model	Number of Teeth	Model	Number of Teeth			
1:1	14M50T86	45	14M50T86	45	280mm	1190	50mm

6) Front Attachment Dimensions

Front Attachment	ΦA	ΦB	ΦC	C	D	E	F	H	G	M
	Male Threaded end	Φ180	Φ140	—	90	150	8	24	—	—
Rod end	Φ180	Φ140	Φ70	—	285	8	55	—	—	—

KMZ245 Dimensions

- Note: When different motors are matched, the dimensions may change.

(P01) Front Flange: L1 = Stroke + 330mm, L2 = Stroke + 668mm

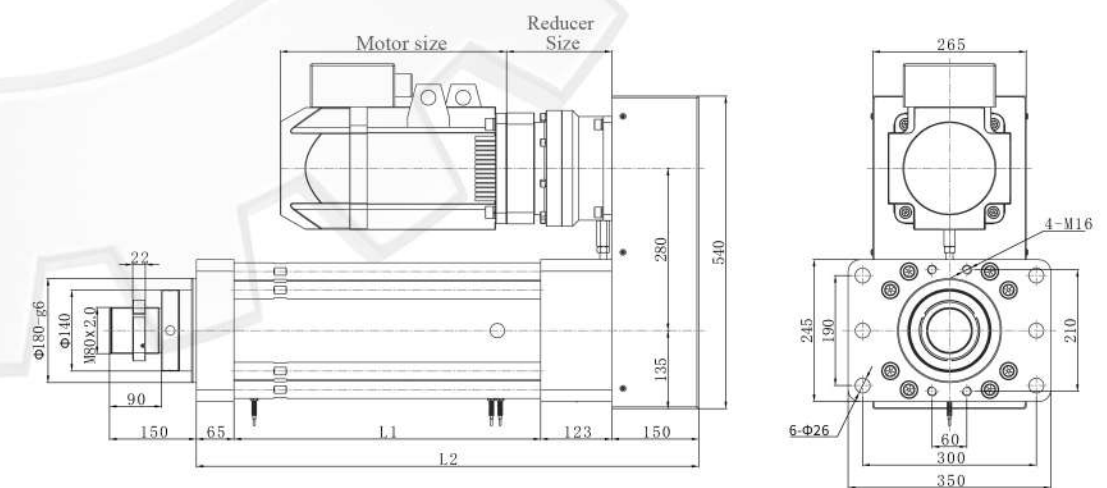

*. Dimensions are subject to change without notice

Specifications and Dimensions
KMZ300 Parameters for Standard Configurations
1) Basic Parameters

- (Note: The Push Load, Stroke and Speed of the Servo Electric Cylinders need to be combined with the actual use, and the three upper limits cannot be used in combination at the same time.) all size, easy installation and use, simple maintenance, low noise, long life, multiple safety protection measures.

Cylinder O.D. (mm)	Cylinder I.D. (mm)	Maximum Push Load	Stroke	Maximum Speed	Rotation Degree of Piston Rod	Limit Switches
Φ280mm	Φ230mm	≤600KN	≤3000mm	≤500mm/s	±0.3°	Proximity Switches

2) Optional

Screw Lead	Ratio	Direct Motor		Planetary Gear Reducer
		Servo Motor Frame	Stepper Motor Frame	
20mm	1:1	—	—	220
25mm		—	—	

3) Screw Parameters

- (Note: The load of the screw is based on Stroke ≤300mm, and the Stroke >300mm needs to consult our technicians.)

Screw Model	Screw Type	Screw Diam.	Screw Lead	Dynamic Load Ca (kN)	Static Load Coa (kN)	Stiffness Kg/μm
JF10020-8	Ball Screw	100mm	20mm	444.9	1526.9	—
JF10025-8	Ball Screw		25mm	603.3	1891.2	—

Screw Model	Ball Diam.	Screw Shaft	Slenderness Ratio	Accuracy Grade / Positioning Accuracy	
JF10020-8	12.7mm	75K20	1:50	C5/±0.01	C7/±0.02
JF10025-8	15.875mm				

4) Bearing Parameters

Bearing Model	Dynamic Load Cr (kN)	Static Load Cor (kN)
Deep Groove Ball Bearings 6217-ZZx2	83.3	63.8
Thrust Spherical Roller Bearings 29417	600	1730

Specifications and Dimensions
5) Synchronous Wheel and Timing Belt Parameters

Ratio	Synchronous Wheels				Timing Belt		
	Drive Wheels		Driven Wheels		Center Distance	Circumference	Width
	Model	Number of Teeth	Model	Number of Teeth			
1:1	14M50T86	45	14M50T86	45	280mm	1190	50mm

6) Front Attachment Dimensions

Front Attachment	ΦA	ΦB	ΦC	C	D	E	F	H	G	M
Male Threaded end	—	—	—	—	—	—	—	—	—	—
Female Threaded end	—	—	—	—	—	—	—	—	—	—
Clevis end	—	—	—	—	—	—	—	—	—	—
Rod end	—	—	—	—	—	—	—	—	—	—
Fork end	—	—	—	—	—	—	—	—	—	—

KMZ300 Dimensions

- Note: When different motors are matched, the dimensions may change.

(P01) Front Flange: L1 = Stroke + 420mm, L2 = Stroke + 692mm

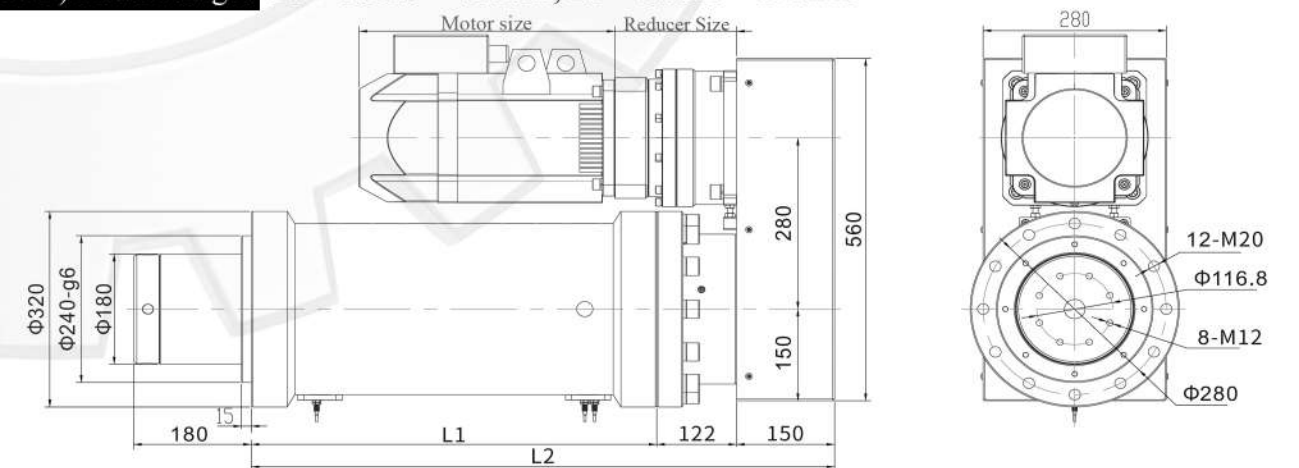

*. Dimensions are subject to change without notice