



## Descriptions

A **Standard Machine Screw Jack** is a type of mechanical actuator that converts rotary motion into linear motion. It typically consists of a gearbox assembly combined with a screw and nut mechanism. Load capacities include **0.5 ton, 1 ton, 2.5 ton, 5 ton, 10 ton, 15 ton, 20 ton, 25 ton, 35 ton, 50 ton and 100 ton.**

### How it works:

A motor or hand crank rotates a worm (input shaft). The worm (input shaft) drives an internal worm gear. This rotation causes the lifting screw to extend or retract linearly.

### Key features and characteristics:

- **Linear actuation:** Machine screw jacks produce a controlled linear movement, suitable for pushing, pulling, lifting, and positioning applications.
- **Load-holding:** Many machine screw jacks are self-locking due to their inherent gear ratios and friction, meaning they can hold heavy loads in position indefinitely without creep, even in the absence of power. However, vibration loads must be avoided.
- **Versatility:** They can be used in single, tandem, or multiple arrangements to lift and position loads at the same speed, even with uneven weight distribution.
- **Precision:** They can offer precise positioning capabilities.
- **Applications:** They are commonly used in various industries for material handling, automated assembly, heavy machinery adjustments, and precise positioning task

### Common designs:

- **Translating screw jacks:** The most common type, where the screw extends and retracts linearly.
- **Keyed screw jacks:** Designed for applications where the lifting screw needs to translate without rotating.
- **Rotating screw jacks:** Where the screw rotates, and a traveling nut attached to the load moves linearly.

### Advantages:

- **High load capacity:** Can handle substantial loads, from a few pounds up to 100 tons.
- **Stability and precision:** Offer controlled and accurate positioning.
- **Reliability:** Have fewer moving parts compared to some other systems.
- **Safety:** Self-locking capability enhances safety in the event of power loss.
- **Environmental friendliness:** Avoid hydraulic oil leaks.
- **Adaptability:** Available in various configurations and with options for different environments.

## Materials

We use the best materials to guarantee the performance and lifetime of the screw jacks you purchased.

### Housing

- High-strength Casting Housing, Ductile Iron.

### Lifting Screw

- C45 Steel as Standard. Custom Stainless Steel 304 or 316.

### Input Shaft (Worm)

- C45 Steel in high frequency heat treatment process. Custom Stainless Steel 304 or 316.

### Worm Gear / Travelling Nut / Safety Nut

- High Strength Bronze ZQA19-4 (Casting aluminum bronze) as Standard, Custom High Strength Bronze ZCuSn10Pb1(Casting tin bronze)

### Bearing

- Anti-friction Ball Thrust Bearings for Worm Gear. Anti-friction Ball Bearings for Input Shaft(worm). Custom Stainless Steel 304.

### Motor Flange Adapter

- High-strength Casting Motor Adapter, Ductile Iron. Custom Stainless Steel 304 or 316.

### Lubricants

- Synthetic Grease, Extreme Pressure EP2 Lithium Grease.

## Materials

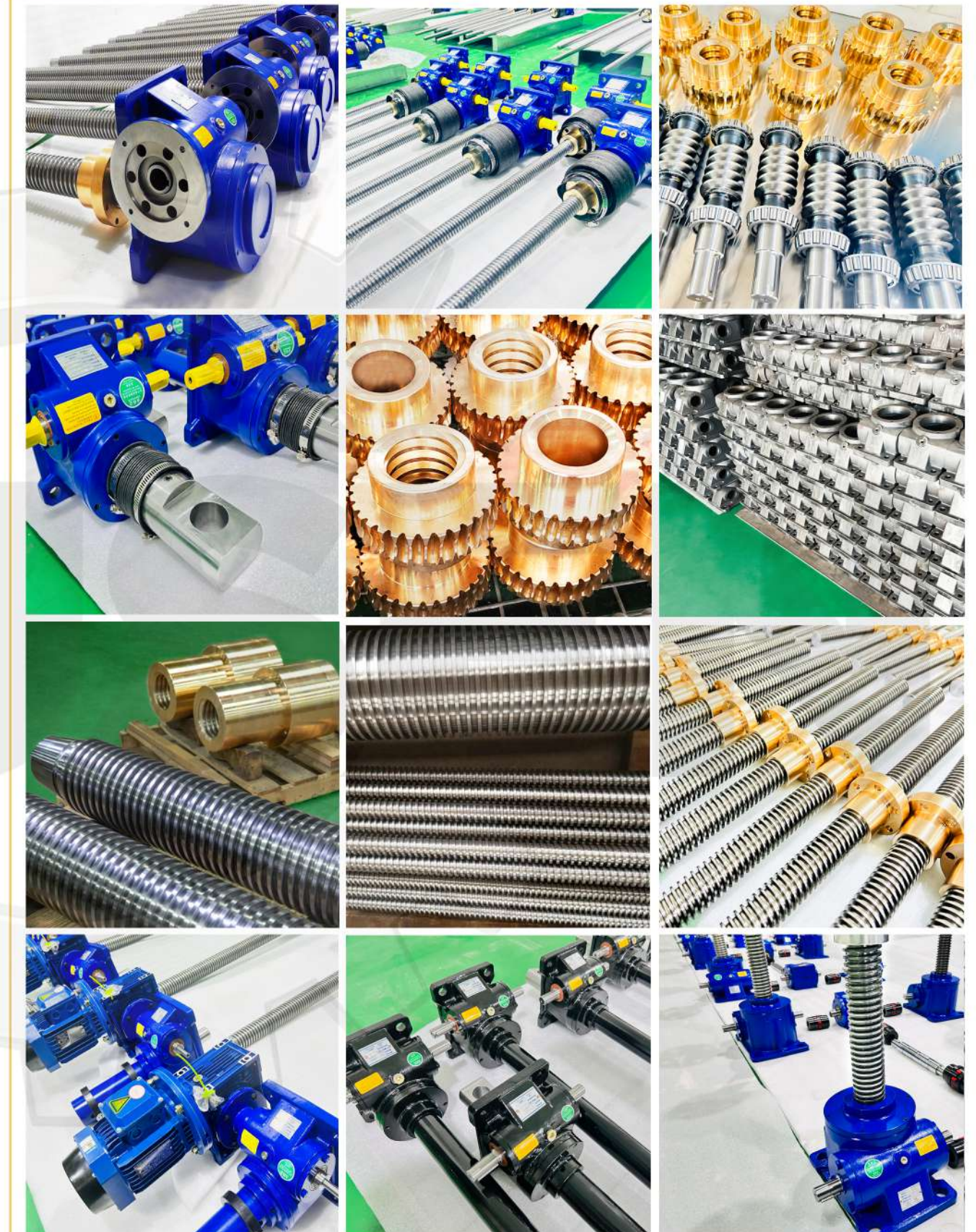



**Selection Guide**

**Selection Notes**

- (01) Screw Jacks and Lifting Systems are for industrial use only, not recommended for transporting personnel.
- (02) Carefully consider jack ratings before making a selection. Be sure that the dynamic or static load carried or sustained by jack does not exceed its maximum capacity.
- (03) Carefully consider the combination of screw shaft speed (rpm) and rated load. Also, take extra care in verifying rated buckling load and screw shaft speed (rpm). Exceeding the data provided in this catalog can cause major damage to the system.
- (04) Make sure that the surface temperature of the housing does not exceed temperature of -15°C to +80°C during operation. If using a traveling nut jack, measure the traveling nut surface temperature. Make sure all the rotating parts are completely stopped before proceeding to measure.
- (05) The maximum input speed is 1500 rpm as long as the input power dose not exceed the jack's maximum allowable input power.
- (06) Screw jack can not be operated continuously. Duty cycle based on 30 minutes.
  - **Note:** Below duty cycles are based on ambient temperatures 20°C. For ambient temperatures higher than 20°C, the duty cycle (ED) must be reduced.
    - \* Screw Jack with Trapezoidal Screw (Machine Screw Jack) duty cycle ≤ 20%ED.
    - \* Screw Jack with Ball Screw (Ball Screw Jack) duty cycle ≤ 30%ED.
  - **Note:** For operation longer than that mentioned above or for any continuous operation, the jacks temperature must be monitored and should not exceed 80°C maximum in order to determine its duty cycle.

**Duty Cycle (%ED) = [1 Duty Cycle / (1 Duty Cycle + 1 Rest Cycle)] x 100%**
- (07) Be sure not to exceed the maximum input torque for multiple screw jack systems by verifying the rated input torque for each jack.
- (08) Be sure that starting torque is 200% or more of required running torque.
- (09) Be sure that ample driving power is available to drive the jack when using in temperatures below 0°C. Low temperatures decrease the jack's efficiency due to the increased grease viscosity inside the jack's gearbox.

**Selection Guide**

- (10) Although Screw Jack with **Single-start** Trapezoidal Screw (Machine Screw Jack) has self-locking feature, vibration and shock may affect its efficiency, in which case a brake motor or extra braking device is required. Screw Jack with **Double-start** Trapezoidal Screw (Machine Screw Jack) is considered not self-locking will require a brake or other holding device. Screw Jack with Ball Screw (Ball Screw Jack) can backdrive because of their extremely high efficiencies and require some means of holding the load, such as a brake motor.
- (11) When jacks are working, can not force to stop, may result in the jacks damage or injury personnel.
- (12) When Ball Screw Jacks are under loads, can not change the motor drive to manual operation. Because the loads will cause the input shaft to rotate very dangerously.
- (13) Mechanical stops (Stop Nuts) are not provided on the lifting screw unless requested. Therefore, it is possible to drive the screw out of the jack's housing.
- (14) Never approach or touch the rotary parts (input shaft, etc.) or the lifting screw during operation.
- (15) Bellows Boots and Protective Tubes should be used to protect and keep the lifting screw clean in dusty or abrasive environments.

**Unit Converter**

- 1 ft = 304.8 mm
- 1 in = 25.4 mm
- 1 m = 10 dm = 100 cm = 1000 mm
- 1 in-lb = 0.113 Nm
- 1 Nm = 0.737 ft-lb
- 1 ft-lb = 1.356 Nm
- 1 lb = 0.454 kg
- 1 kg = 2.205 lb = 1000 g
- 1 N = 0.1 kg
- 1 t = 1000 kg = 10 kN = 2000 lb
- 1 m/min = 1000 mm/min = 16.7 mm/sec
- 1 in/sec = 25.4 mm/sec
- 1 ft/sec = 304.8 mm/sec
- 1 hp = 0.75 kW
- °C = (°F-32) / 1.8
- °F = °C x 1.8 + 32



**Selection Guide**

**Calculation Formulas**

■ **(01) Calculate Total Load Ws (N)**

$$W_s = W \times sf$$

Ws = Total Load (N)

W = Maximum Load (N)

sf = Safety Factor (Table 1.)

**Table 1. Safety Factor sf**

Load Conditions	Example Purposes	Safety Factor (sf)
Smooth movement with no shock, Light load	Opening and closing a valve, Adjusting a conveyor	1.0 ~ 1.3
Light shock, Medium load	Use with various kinds of transporting equipment and lifters	1.3 ~ 1.5
Severe shock and/or vibration, Heavy load	Use with large transporting carriages, Holding the position of a press roller	1.5 ~ 3.0

• **Note:** The above table is for general reference only. Consider particular operating conditions under which you operate before selecting a safety factor.

■ **(02) Calculate Load Per Jack Wn (N)**

$$W_n = W_s / (N_o \times fd \times \eta_g)$$

• **Note:** For a synchronous drive, use a synchronous drive coefficient (Table 2).

• **Note:** Don't ignore spiral bevel gearbox efficiency 94%.

Wn = Load Per Jack (N)      Ws = Total Load (N)

No = Number of jacks      fd = Multiple jacks system coefficient (Table 2.)

ηg = Bevel Gearbox efficiency = 94%

**Table 2. Multiple Jacks System Coefficient fd**

No. of jacks	1	2	3	4	5 ~ 8
Coefficient	1	0.95	0.9	<b>0.85</b>	0.8

■ **(03) Jack Selection**

Follow these steps to make a preliminary jack selection.

**Points of preliminary jack selection**

- Select (temporary) worm speed ratio by adjusting the screw shaft rpm. If difficult to select, inspect by H speed.
- Consider traveling space when selecting stroke.
- Select options based on your needs.

**Selection Guide**

■ **(04) Verifying Allowable Buckling Load Pcr (N)**

For a compressive load, verify that it does not exceed the allowable buckling load. If it does, increase jack size and recalculate.

$$P_{CR} = f_m \times (d^2 / L)^2, \text{ Make Sure } P_{CR} > W_n \times sf \text{ (sf = 4 as usual)}$$

Pcr = Allowable buckling load (N)

f<sub>m</sub> = Support coefficient (Table 4.)

L = Distance between load-supporting plane(point) and mounting plane(point) (mm)

**d = Screw shaft root diameter (mm) = D - TP - 2 x ac**      TP = Screw pitch (mm)

W<sub>n</sub> = Load Per Jack (N)      D = Screw diameter (mm)      ac = Assembly clearance (Table 3.)

**Table 3. Assembly Clearance ac**

Screw Pitch (mm)	ac
1.5 - 5	0.25
6 - 12	0.5
14 - 44	1

**Table 4. Support Coefficient fm**

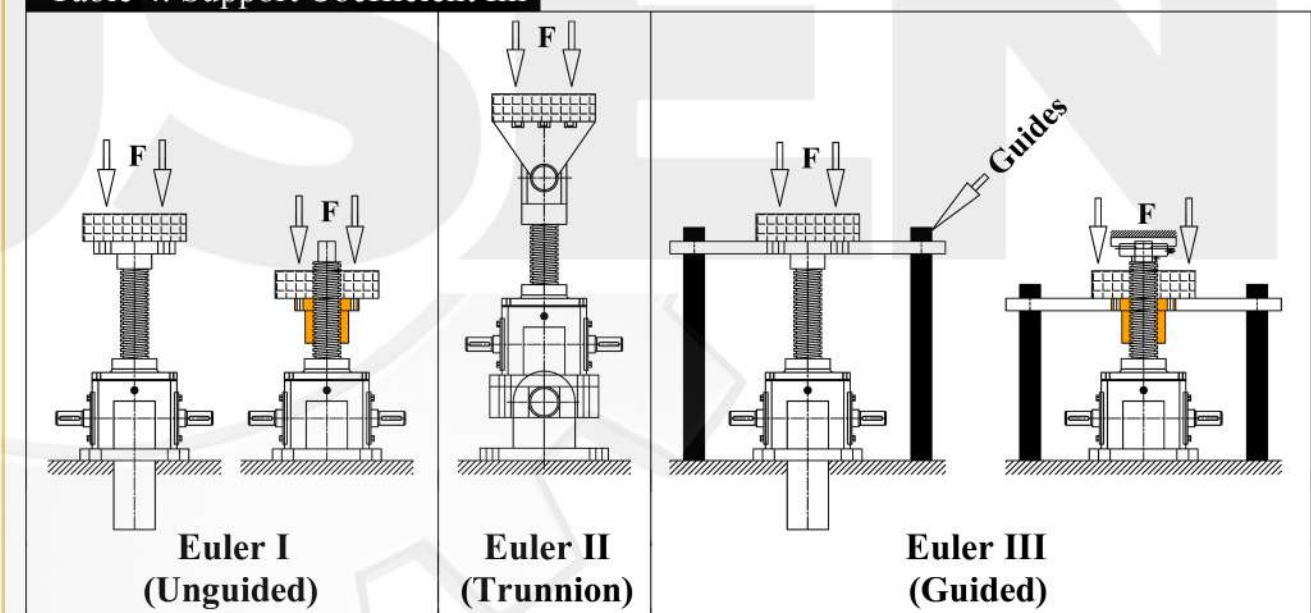

- **Euler I (fm = 2.5 x 10<sup>4</sup>):** Screw jack housing fixed to the base (foot-mounted). Lifting screw end (or travelling nut) lifting the free load (unguided).
- **Euler II (fm = 1 x 10<sup>5</sup>):** Screw jack housing and lifting screw end (or travelling nut) are trunnion mounted by pin or joint for pivot drive.
- **Euler III (fm = 2 x 10<sup>5</sup>):** Screw jack housing fixed to the base (foot-mounted). Lifting screw end (or travelling nut) lifting the fixed load (guided).

**Selection Guide**
**Calculation Formulas**
**(05) Verifying Allowable Screw Speed  $N_C$  (rpm)**

- **Note:** Only for Screw Jack with Traveling Nut (Rotating Screw Jack), verify that it does not exceed the allowable screw shaft rpm. If it does, increase jack size and recalculate.

$$N_C = (96 \times f_n \times d \times 10^6) / L^2, \text{ Make Sure } N_C > n_2, n_2 = n_1 / i$$

$N_C$  = Allowable screw shaft speed (rpm)       $f_n$  = Shaft end support coefficient (Table 5.)

$L$  = Distance between load-supporting plane and mounting plane (mm) (Table 5.)

$d$  = Screw shaft root diameter (mm) =  $D - TP - 2x_{ac}$        $TP$  = Screw pitch (mm)

$D$  = Screw diameter (mm)

$ac$  = Assembly clearance (Table 3.)

$n_2$  = Output speed of screw shaft (rpm)

$n_1$  = Input speed of worm shaft (rpm)

$i$  = Gear ratio

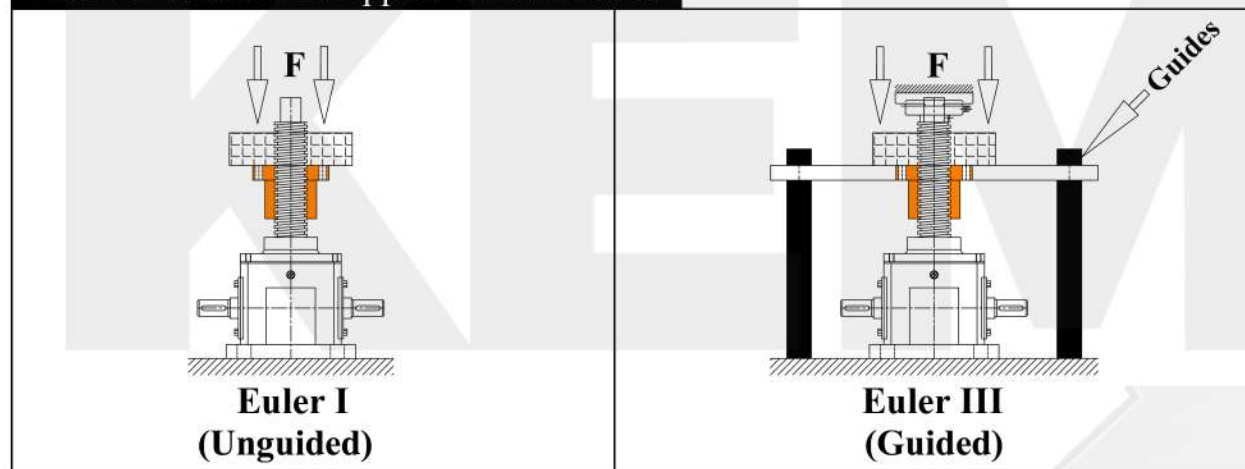
**Table 5. Shaft End Support Coefficient  $f_n$** 

- **Euler I ( $f_n = 0.36$ ):** Screw jack housing fixed to the base (foot-mounted). Travelling nut lifting the free load (unguided).
- **Euler III ( $f_n = 1.56$ ):** Screw jack housing fixed to the base (foot-mounted). Travelling nut lifting the fixed load (guided).

**(06) Confirming Required Input Speed  $n_1$  (rpm)**

Determine the required input rpm, using the required screw shaft speed.

- **Note:** Input speed should not exceed 1500 rpm.

$$n_1 = v \times i / TP$$

$v$  = Lifting speed (mm/min)

$n_1$  = Input speed of worm shaft (rpm)

$TP$  = Screw pitch (mm)

$i$  = Gear ratio

**Selection Guide**
**(07) Verifying Required Input Torque per  $T$  (Nm)**

$$T = (F_{dyn} \times TP) / (2 \times \pi \times \eta \times i) + T_o$$

$F_{dyn}$  = Dynamic axial force (= lifting force) (kN)       $F_{stat}$  = Static axial force (= retention force) (kN)

$TP$  = Screw pitch (mm)

$\pi = 3.1416$

$\eta$  = Screw jack efficiency (see the Specifications of Jack Series)

\* For Machine Screw Jacks, normal  $\eta = 0.15$  (H ratio),  $\eta = 0.12$  (L ratio)

\* For Ball Screw Jacks, normal  $\eta = 0.3\sim 0.35$  (H ratio),  $\eta = 0.22$  (L ratio)

$i$  = Gear ratio

$T_o$  = Idling torque (Nm) (see the Specifications of Jack Series)

**(08) Verifying Required Input Power  $P$  (kW)**

$$P = W_1 \times v_1 / (6000 \times \eta)$$

$P$  = Input power (kW)

$W_1$  = Lifting force (kgf)

$v_1$  = Lifting speed (m/min)

$\eta$  = Screw jack efficiency (see the Specifications of Jack Series)

\* For Machine Screw Jacks, normal  $\eta = 0.15$  (H ratio),  $\eta = 0.12$  (L ratio)

\* For Ball Screw Jacks, normal  $\eta = 0.3\sim 0.35$  (H ratio),  $\eta = 0.22$  (L ratio)

**(09) Other Calculation Formulas**

09.01) Lifting Speed:  $v = n_1 \times TP / i$

09.02) Stroke / Revolution:  $SR = TP / i$

09.03) Input Torque:  $T = 9550 \times P / n_1 + T_o$

09.04) Input Power:  $P = T \times n_1 / 9550$

09.05) Starting Torque per Jack:  $T_{st} \approx T \times 1.3$

09.06) Hand Wheel Turning Force:  $W_{hw} = T / R_{hw}$

09.07) Input Power of Multiple Jacks System:  $P_s = P \times N_o / (fd \times \eta_g)$

09.08) Input Torque of Multiple Jacks System:  $T_s = T \times N_o / (fd \times \eta_g)$

09.09) Screw Shaft Pitch Diameter:  $d_2 = D - 0.5 \times TP$

09.10) Screw Shaft Torque:  $T_{hub} = F_{dyn} \times (d_2 / 2) \times \tan(\alpha \pm \phi)$ ,  $\phi \approx 6^\circ$

09.11) Lead Angle:  $\alpha = \arctan[TP / (d_2 \times \pi)]$

- **Note:** A prerequisite is a vibration-free operation

\* Self-locking at standstill (Static):  $2.4^\circ < \alpha < 4.5^\circ$ , may require brake motor

\* Self-locking from movement (Dynamic):  $\alpha < 2.4^\circ$ , don't require brake motor

\* No self-locking:  $\alpha > 4.5^\circ$ , require brake motor

**Selection Guide**
**Calculation Formulas**

 09.12) Duty cycle based on 1 hour:  $ED = [S \times As \times 5 / (3 \times v)] \times 100\%$ 

 09.13) Ball Screw Service Life in Hours:  $L_h = (C_{dyn} / F_{dyn})^3 \times 10^6 / (n_2 \times 60)$ ,  $n_2 = n_1 / i$ 

- **Note:** Trapezoidal Screw Service Life cannot be determined by the formula used to calculate a Ball Screw wear life. Use the information below as a reference.  
50kN(5 ton) and below models average expected life 5000 meters.  
100kN(10 ton) and above average expected life 1000 meters.

 $v$  = Lifting speed (mm/min)

 $n_1$  = Input speed of worm shaft (rpm)

 $n_2$  = Output speed of screw shaft (rpm)

 $TP$  = Screw pitch (mm)

 $i$  = Gear ratio

 $SR$  = Stroke / Revolution (mm)

 $N_o$  = Number of jacks

 $fd$  = Multiple jacks system coefficient (**Table 2.**)

 $\eta_g$  = Bevel Gearbox efficiency,  $\eta_g \approx 94\%$ 
 $P$  = Input power per jack (kW)

 $P_s$  = Input power of multiple jacks system (kW)

 $T_o$  = Idling torque (Nm)

 $T$  = Input torque per jack (Nm)

 $T_s$  = Input torque of multiple jacks system (Nm)

 $T_{st}$  = Starting torque per jack (Nm)

 $T_{hub}$  = Screw Shaft Torque (Nm)

 $L_h$  = Ball screw service life in hours (h)

 $C_{dyn}$  = Dynamic load capacity of ball screw (kN)

 $F_{dyn}$  = Dynamic axial force (= lifting force) (kN)

 $\alpha$  = Lead Angle (°)

 $\phi$  = Dynamic friction angle (°)

 $d_2$  = Pitch diameter (mm)

 $D$  = Screw shaft diameter (mm)

 $W_{hw}$  = Hand wheel turning force (N)

 $R_{hw}$  = Hand wheel radius (m)

 $\pi = 3.1416$ 
 $ED$  = Duty Cycle (%/hr)

 $S$  = Length of Stroke (mm)

 $As$  = Number of load cycles (up and down movement).

- \* **Example:** 5 times in and out movement of the screw shaft equals 10 double strokes.

**Selection Guide**
**Sample Part Number ( Example ) :**
**KMC1TLAS300CESLRZB**
**(1) Models and Gear Ratios**

KMC0.5T (Tr16x4) H=1:5 L=1:20	KMC1T (Tr24x4) H=1:6 L=1:24	KMC2.5T (Tr30x6) H=1:6 L=1:24	KMC5T (Tr40x7) H=1:6 L=1:24	KMC10T/15T (Tr58x12) H=1:8 L=1:24	KMC20T (Tr65x12) H=1:8 L=1:24
KMC25T (Tr90x16) H=1:10-2/3 L=1:32	KMC35T (Tr100x20) H=1:10-2/3 L=1:32	KMC50T (Tr120x20) H=1:10-2/3 L=1:32	KMC100T (Tr160x24) H=1:12 L=1:36	<b>H:</b> High ratio <b>L:</b> Slow ratio	

**1.1) Model Note 1:** the model indicates the maximum static load of this screw jack, but not the Maximum dynamic load. The dynamic load depends on the lifting speed, travel length and others working conditions.

**1.2) Model Note 2:** The slower the lifting speed, the greater the dynamic load.

**1.3) Model Note 3:** In the case of compressed loads and long strokes, please calculate maximum critical buckling force.

**1.4) Gear Ratio Note 1:** Screw jacks with gear ratios between 20:1 and 56:1, are self-locking and, in the absence of vibration, will hold loads without backdriving. All other ratios may require a brake to prevent backdriving.

**1.5) Gear Ratio Note 2:** Every screw jack model with 2 gear ratios as a standard. Custom others gear ratios.

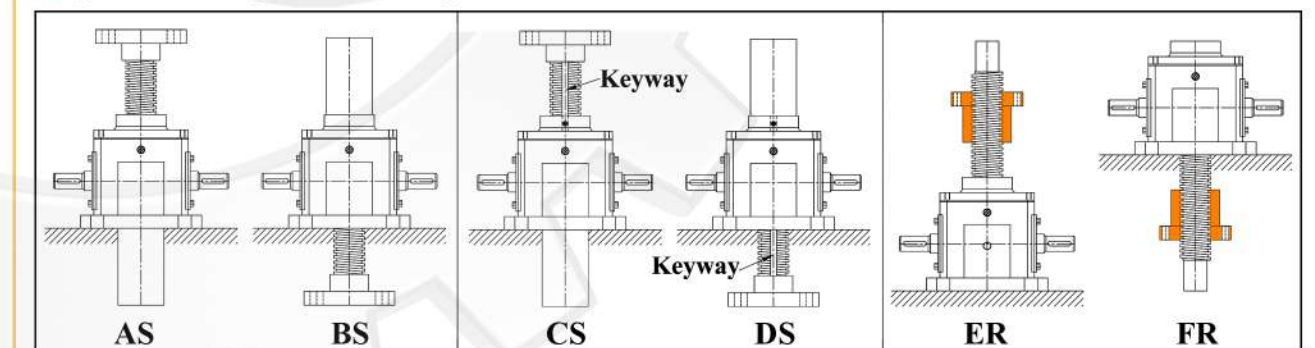
**(2) Basic Designs and Configurations**

**2.1) "AS" and "BS" are Translating Screw Jacks,** they are the most commonly specified

jack. All that is required for proper function is to restrain the rotation of the lifting screw and apply torque to the input shaft. This is often achieved through the use of guides (guided load) or by attaching a common load across multiple jacks. Most applications use this jack design.

**Selection Guide**

**Sample Part Number**

2.2) “CS” and “DS” are **Keyed Screw Jacks**, they are keyed for non-rotation. It is ideal for use in applications where a single jack must extend to meet and move a load to which it is not attached (unguided). Keyed jacks are commonly used in single jack applications where it would not otherwise be possible to restrain the rotation of the jack screw.

- **Note:** Input torque required will increase by approximately 8%.
- **Note:** Custom square protective tube for Anti-rotation Screw Jacks, a square nut is attached to the end of the lifting screw which is then fitted inside the tube, to prevent rotation.

2.3) “ER” and “FR” are **Rotating Screw Jacks**, they are also called travelling nut screw jack. It is important to restrain the rotation of the traveling nut by applying a significant load, or more commonly by guiding the load or attaching the load across multiple jacks. The Rotating Jacks mount flush and they are ideal for applications where the physical space does not allow the lifting screw to extend below or above the housing.

2.4) Custom double clevis screw jacks, trunnion mount screw jacks and anti-backlash nut screw jacks.

■ (3) Stroke and Screw End Fittings

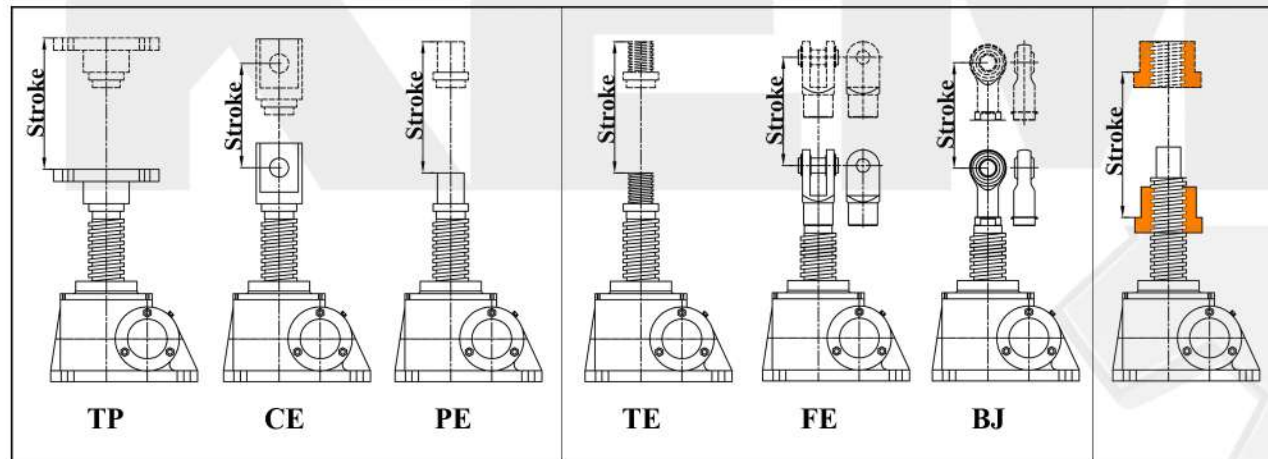

- Stroke is travel expressed in millimeter(mm) or inches and not the actual screw length.
- Standard Lifting Screw End Fittings: (TP)Top Plate , (CE)Clevis End , (PE)Plain End , (TE)Threaded End , (FE)Forked End and (BJ)Rod End . Custom End Fittings are acceptable.

**Selection Guide**

■ (4) Input Shafts Codes and Motor Flange Adapters Codes (Top View)

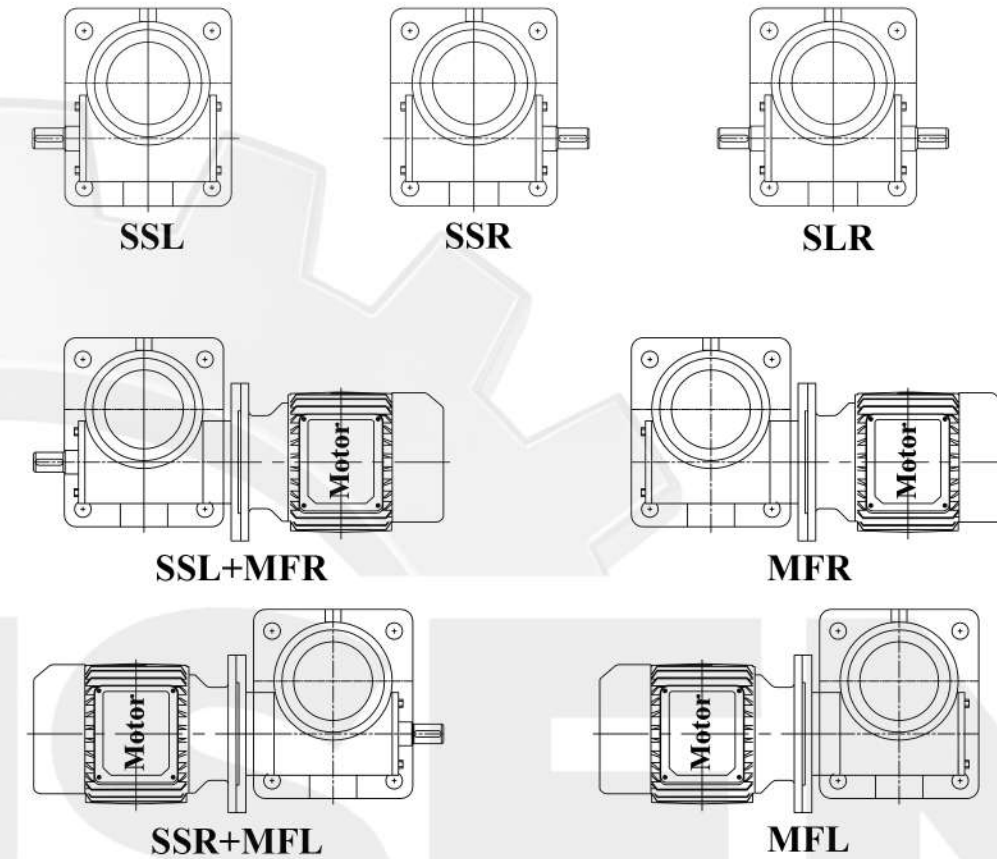

- 4.1) **SSL:** Single Input, Left Side Shaft.
- 4.2) **SSR:** Single Input, Right Side Shaft.
- 4.3) **SLR:** Double Input Shafts
- 4.4) **SSL+MFR:** Left Side Shaft, Right Side Motor Flange Adapter (Motor Mounts).
- 4.5) **MFR:** Right Side Motor Flange Adapter (Motor Mounts).
- 4.6) **SSR+MFL:** Right Side Shaft, Left Side Motor Flange Adapter (Motor Mounts).
- 4.7) **MFL:** Left Side Motor Flange Adapter (Motor Mounts).

- **Note:** Screw Jacks with IEC Motor Flange Adapter as a standard. Custom NEMA Motor Flange Adapter(Stepper Motor), Servo Motor Flange Adapter and Other Non-standard Motor Flange Adapters.

## Selection Guide

### Sample Part Number

#### (5) Accessories

<b>C</b> Flex Coupling	<b>U</b> Universal Joint	<b>T</b> Telescopic Universal Joint	<b>L</b> Connecting Shaft	<b>BJ</b> Rod End	<b>FE</b> Fork End
<b>PB</b> Pillow Blocks	<b>FB</b> Flange Blocks	<b>Z</b> Protective Tube	<b>B</b> Bellows Boots	<b>SN</b> Stop Nut	
<b>MF</b> Motor Flange	<b>SP</b> Trunnion Mount Plate	<b>SF</b> Safety Nut	<b>DZ</b> Double Clevis Protective Tube	<b>FZ</b> Square Protective Tube	
<b>M</b> Electric Motor	<b>R</b> Geared Motor	<b>K</b> Bevel Geared Motor	<b>RV</b> Worm Gearbox	<b>DC</b> DC Motor	
<b>SM1</b> Stepper Motor	<b>SM2</b> Servo Motor	<b>CH</b> Hand Wheel	<b>EN</b> Rotary Encoder	<b>P</b> Proximity Switch	

## Permissible Buckling Load

If the lifting screw is loaded in tension, the buckling can be avoided, and hence be highly economical. In case of compression load, even occasional, it is necessary to check the buckling structure. Because the thin lifting screws may buckle sideways when subjected to compressive loads.

The permissible buckling load for trapezoidal-screw and ball-screw can be verified using the following bend diagrams. Verify that it does not exceed the permissible buckling load. If it does, increase jack size and recalculate.

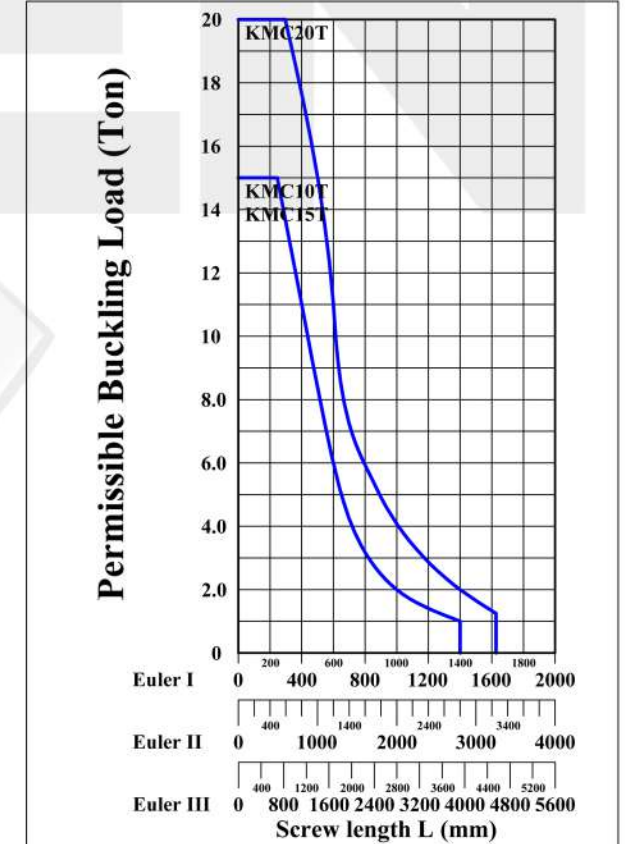
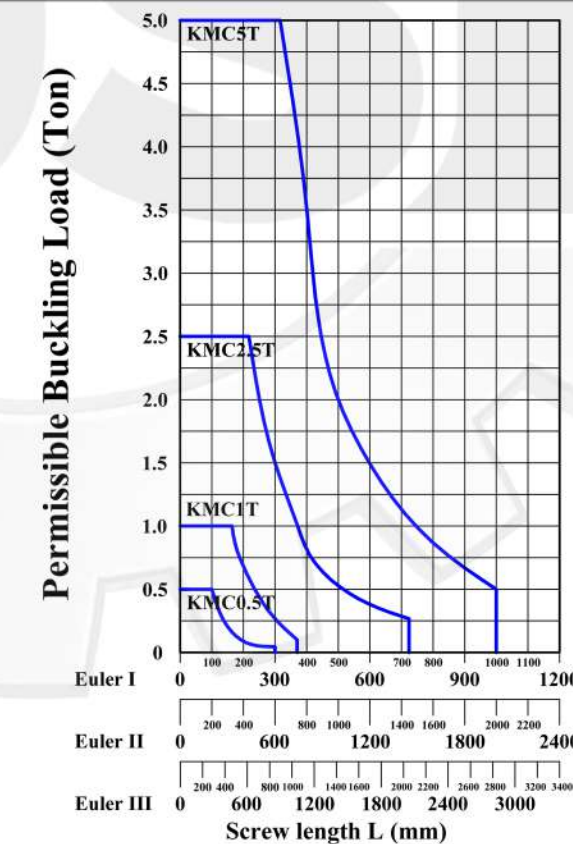
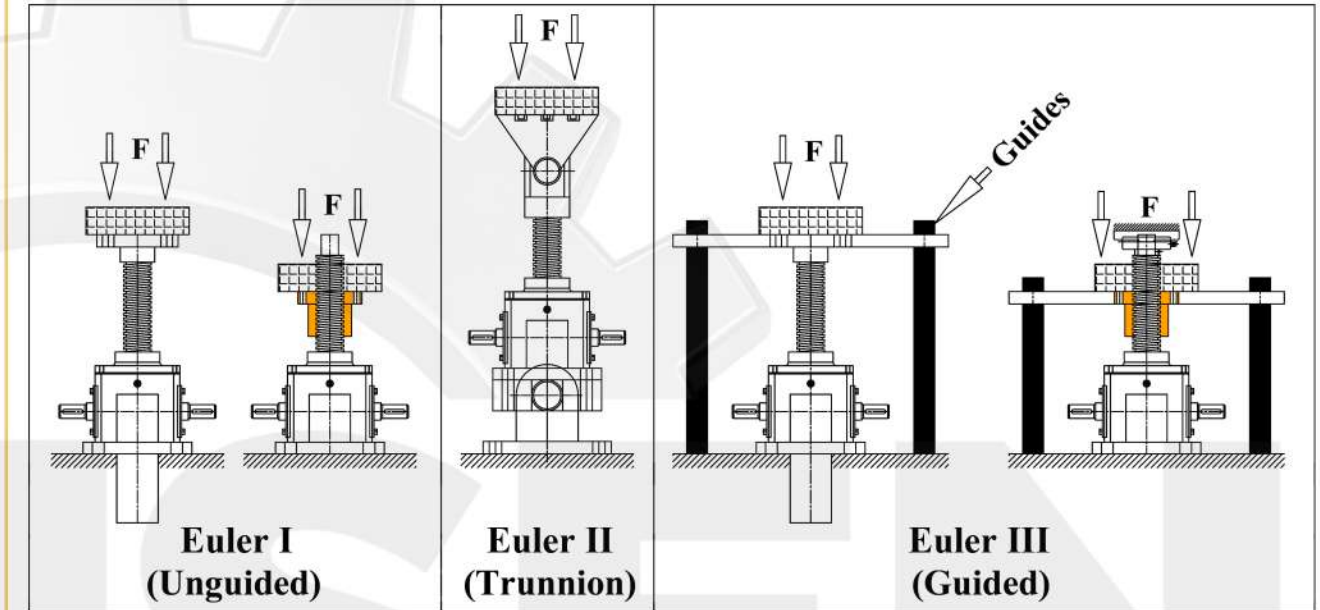

**Permissible Buckling Load**

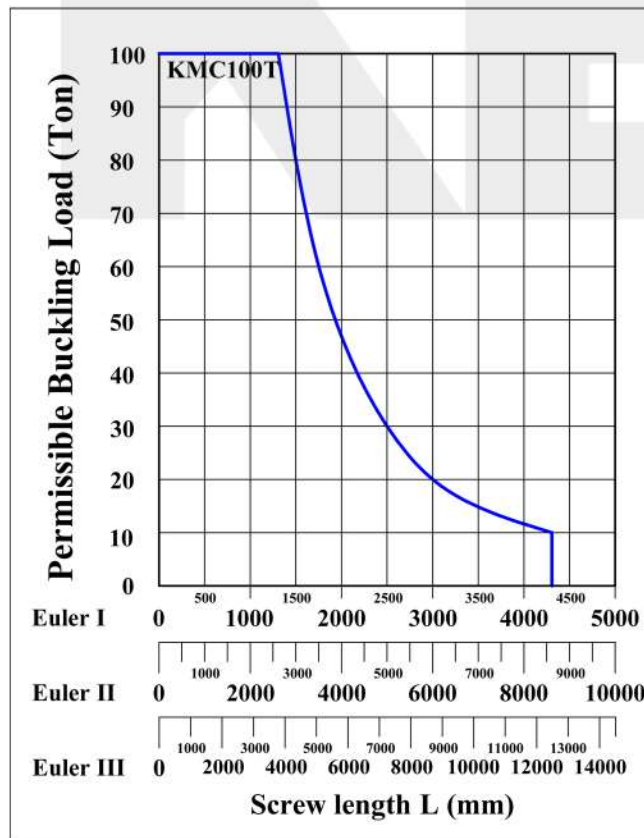
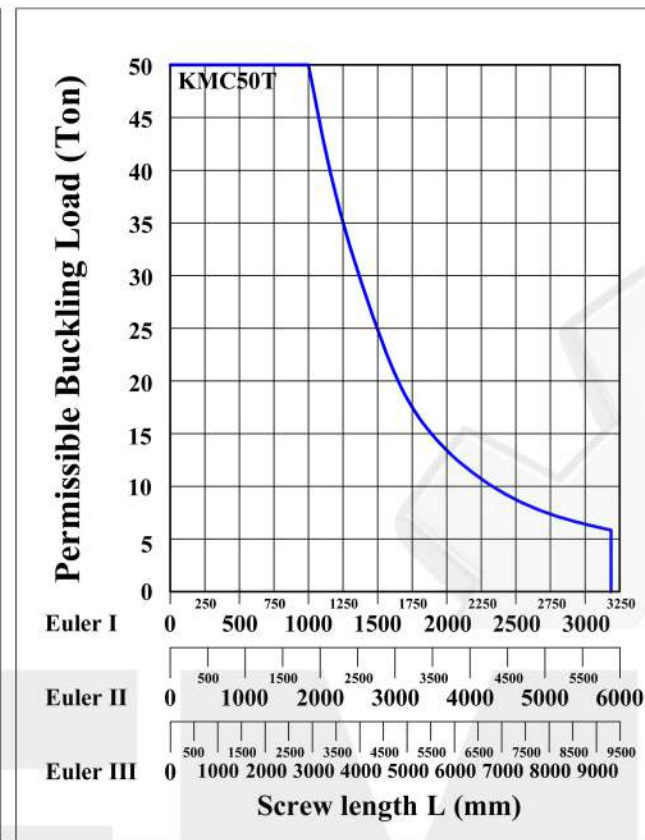
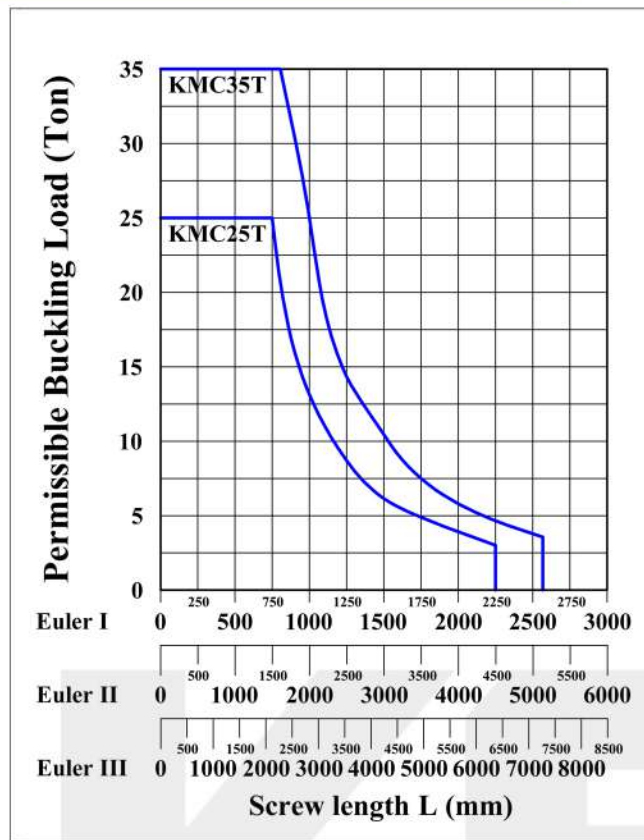

**Specifications**

• **Remarks:**

- 1) H: high ratio, L: slow ratio
- 2) Max. allowable power is under the conditions that ambient temperature 20 degree C, duty cycle 20%h and input speed 1500rpm
- 3) Overall efficiency is under grease lubrication.
- 4) Self-locking under static conditions.

Model	KMC0.5T	KMC1T	KMC2.5T	KMC5T	KMC 10T/15T	KMC20T	KMC25T	KMC35T	KMC50T	KMC100T
Max. lifting force (ton)	0.5	1	2.5	5	10	20	25	35	50	100
Max. pulling force (ton)	0.5	1	2.5	5	9.9	16.6	25	35	50	100
Lift screw sizes (mm)	Tr16 x 4	Tr24 x 4	Tr30 x 6	Tr40 x 7	Tr58 x 12	Tr65 x 12	Tr90 x 16	Tr100 x 20	Tr120 x 20	Tr160 x 24
Gear ratio (H)	5:1	6:1	6:1	6:1	8:1	8:1	32:3	32:3	32:3	12:1
Lift screw travel (mm), per turn of input shaft (H)	0.8	0.667	1	1.167	1.5	1.5	1.5	1.875	1.875	2
Efficiency % (H)	20	21	23	21	23	21	19	18	15	13
Gear ratio (L)	20:1	24:1	24:1	24:1	24:1	24:1	32:1	32:1	32:1	36:1
Lift screw travel (mm), per turn of input shaft (L)	0.2	0.167	0.25	0.292	0.5	0.5	0.5	0.625	0.625	0.67
Efficiency % (L)	12	13	14	12	15	13	11	11	11	10
Max. length of lift screw (mm), when max. tensile force	800	1200	1500	2000	2500	3000	3500	4000	5500	6500
Max. allowable power (kw)	0.18	0.25	0.55	1.1	2.6	3.7	4.8	6	7.5	15
Gear housing material	Ductile Iron	Ductile Iron		Stainless Steel			Ductile Iron			
Lubricant (kg)	0.03	0.05	0.1	0.25	0.5	0.75	1.1	1.9	2.2	2.5
Weight without stroke (kg)	2.5	4	7.3	16.2	25	36	70.5	87	420	1010
Weight of screw (kg), per 100 mm stroke	0.15	0.3	0.45	0.82	1.67	2.15	4.15	5.2	7.45	13.6



**Performance Tables**

- **Note:** The dark gray figures in the tables indicates operational restrictions due to thermal limits. Static only (dynamic not permitted). Selection of screw jacks using these figures should only be carried out in consultation with our engineers. When your selection is made within the areas dark gray, you will need to reduce duty cycle or choose larger model screw jacks in order to allow effective heat dissipation.
- **Conditions:** Duty cycle 20%/h or 30%/10min, 20 °C ambient temperature.
- **Gear Ratios:** H: high ratio, L: slow ratio.
- **Nm:** Input torque required, **kW:** Input power required.

**KMC1T(Tr24x4)**

Input Speed (RPM)	Lifting Speed (MM/MIN)		F=1 Ton		F=0.8 Ton		F=0.6 Ton		F=0.4 Ton		F=0.3 Ton		F=0.2 Ton		F=0.1 Ton	
			H	L	H	L	H	L	H	L	H	L	H	L	H	L
	H	L	kW	kW	kW	kW	kW	kW	kW	kW	kW	kW	kW	kW	kW	kW
1500	1000.0	250.0	1.00	0.40	0.80	0.32	0.60	0.24	0.40	0.16	0.30	0.12	0.20	0.08	0.10	0.04
1000	666.7	166.7	0.67	0.27	0.53	0.21	0.40	0.16	0.27	0.11	0.20	0.08	0.13	0.05	0.07	0.03
750	500.0	125.0	0.50	0.20	0.40	0.16	0.30	0.12	0.20	0.08	0.15	0.06	0.10	0.04	0.05	0.02
500	333.3	83.3	0.33	0.13	0.27	0.11	0.20	0.08	0.13	0.05	0.10	0.04	0.07	0.03	0.03	0.01
300	200.0	50.0	0.20	0.08	0.16	0.06	0.12	0.05	0.08	0.03	0.06	0.02	0.04	0.02	0.02	0.01
200	133.3	33.3	0.13	0.05	0.11	0.04	0.08	0.03	0.05	0.02	0.04	0.02	0.03	0.01	0.01	0.01
100	66.7	16.7	0.07	0.03	0.05	0.02	0.04	0.02	0.03	0.01	0.02	0.01	0.01	0.01	0.01	0.00
50	33.3	8.3	0.03	0.01	0.03	0.01	0.02	0.01	0.01	0.01	0.01	0.00	0.01	0.00	0.00	0.00

**KMC2.5T(Tr30x6)**

Input Speed (RPM)	Lifting Speed (MM/MIN)		F=2.5 Ton		F=2.0 Ton		F=1.5 Ton		F=1.0 Ton		F=0.5 Ton		F=0.25 Ton		F=0.1 Ton	
			H	L	H	L	H	L	H	L	H	L	H	L	H	L
	H	L	kW	kW	kW	kW	kW	kW	kW	kW	kW	kW	kW	kW	kW	kW
1500	1500	375	2.70	1.20	2.20	0.89	1.70	0.67	1.10	0.45	0.54	0.22	0.27	0.11	0.11	0.05
1000	1000	250	1.80	0.74	1.50	0.60	1.10	0.45	0.72	0.30	0.36	0.15	0.18	0.07	0.07	0.05
750	750	187.5	1.40	0.56	1.10	0.45	0.82	0.33	0.54	0.22	0.27	0.11	0.14	0.06	0.05	0.05
500	500	125	0.91	0.37	0.72	0.30	0.54	0.22	0.36	0.15	0.18	0.07	0.09	0.05	0.05	0.05
300	300	75	0.54	0.22	0.43	0.18	0.33	0.13	0.22	0.09	0.11	0.05	0.05	0.05	0.05	0.05
200	200	50	0.36	0.15	0.29	0.12	0.22	0.09	0.14	0.06	0.07	0.05	0.05	0.05	0.05	0.05
100	100	25	0.18	0.07	0.14	0.06	0.11	0.05	0.07	0.05	0.05	0.05	0.05	0.05	0.05	0.05
50	50	12.5	0.09	0.05	0.07	0.05	0.05	0.05	0.05	0.05	0.05	0.05	0.05	0.05	0.05	0.05

**Performance Tables**

**KMC5T(Tr40x7)**

Input Speed (RPM)	Lifting Speed (MM/MIN)		F=5 Ton		F=4 Ton		F=3 Ton		F=2 Ton		F=1 Ton		F=0.5 Ton		F=0.25 Ton	
			H	L	H	L	H	L	H	L	H	L	H	L	H	L
	H	L	kW	kW	kW	kW	kW	kW	kW	kW	kW	kW	kW	kW	kW	kW
1500	1750.0	437.5	6.90	3.00	5.60	2.40	4.20	1.80	2.80	1.20	1.40	0.60	0.70	0.30	0.30	0.20
1000	1166.7	291.7	4.60	2.00	3.70	1.60	2.80	1.20	1.90	0.80	0.90	0.40	0.50	0.20	0.20	0.10
750	875.0	218.8	3.50	1.50	2.80	1.20	2.10	0.90	1.40	0.60	0.70	0.30	0.30	0.20	0.20	0.10
500	583.3	145.8	2.30	1.00	1.90	0.80	1.40	0.60	0.90	0.40	0.50	0.20	0.20	0.10	0.10	0.10
300	350.0	87.5	1.40	0.60	1.10	0.50	0.80	0.40	0.60	0.20	0.30	0.10	0.10	0.10	0.10	0.10
200	233.3	58.3	0.90	0.40	0.70	0.30	0.60	0.20	0.40	0.20	0.20	0.10	0.10	0.10	0.10	0.10
100	116.7	29.2	0.50	0.20	0.40	0.20	0.30	0.10	0.20	0.10	0.10	0.10	0.10	0.10	0.10	0.10
50	58.3	14.6	0.20	0.10	0.20	0.10	0.10	0.10	0.10	0.10	0.10	0.10	0.10	0.10	0.10	0.10

**KMC10T(Tr58x12)**

Input Speed (RPM)	Lifting Speed (MM/MIN)		F=10 Ton		F=8 Ton		F=6 Ton		F=4 Ton		F=2 Ton		F=1 Ton		F=0.5 Ton	
			H	L	H	L	H	L	H	L	H	L	H	L	H	L
	H	L	kW	kW	kW	kW	kW	kW	kW	kW	kW	kW	kW	kW	kW	kW
1500	2250	750	17.00	8.30	14.00	6.70	11.00	5.00	6.80	3.30	3.40	1.70	1.70	0.80	0.90	0.40
1000	1500	500	12.00	5.60	9.10	4.40	6.80	3.30	4.50	2.20	2.30	1.10	1.10	0.60	0.60	0.30
750	1125	375	8.50	4.20	6.80	3.30	5.10	2.50	3.40	1.70	1.70	0.80	0.90	0.40	0.40	0.20
500	750	250	5.70	2.80	4.50	2.20	3.40	1.70	2.30	1.10	1.10	0.60	0.60	0.30	0.30	0.10
300	450	150	3.40	1.70	2.70	1.30	2.00	1.00	1.40	0.70	0.70	0.30	0.30	0.20	0.20	0.10
200	300	100	2.30	1.10	1.80	0.90	1.40	0.70	0.90	0.40	0.50	0.20	0.20	0.10	0.10	0.10
100	150	50	1.10	0.60	0.90	0.40	0.70	0.30	0.50	0.20	0.20	0.10	0.10	0.10	0.10	0.10
50	75	25	0.60	0.30	0.50	0.20	0.30	0.20	0.20	0.10	0.10	0.10	0.10	0.10	0.10	0.10





**Performance Tables**

**KMC15T(Tr58x12)**

Input Speed (RPM)	Lifting Speed (MM/MIN)		F=15 Ton		F=10 Ton		F=8 Ton		F=6 Ton		F=4 Ton		F=2 Ton		F=1 Ton	
			H	L	H	L	H	L	H	L	H	L	H	L	H	L
	H	L	kW	kW	kW	kW	kW	kW	kW	kW	kW	kW	kW	kW	kW	kW
1500	2250	750	26.00	15.00	17.00	8.30	14.00	6.70	11.00	5.00	6.80	3.30	3.40	1.70	1.70	0.80
1000	1500	500	17.00	9.60	12.00	5.60	9.10	4.40	6.80	3.30	4.50	2.20	2.30	1.10	1.10	0.60
750	1125	375	13.00	7.20	8.50	4.20	6.80	3.30	5.10	2.50	3.40	1.70	1.70	0.80	0.90	0.40
500	750	250	8.50	4.80	5.70	2.80	4.50	2.20	3.40	1.70	2.30	1.10	1.10	0.60	0.60	0.30
300	450	150	5.10	2.90	3.40	1.70	2.70	1.30	2.00	1.00	1.40	0.70	0.70	0.30	0.30	0.20
200	300	100	3.40	1.90	2.30	1.10	1.80	0.90	1.40	0.70	0.90	0.40	0.50	0.20	0.20	0.10
100	150	50	1.70	1.10	1.10	0.60	0.90	0.40	0.70	0.30	0.50	0.20	0.20	0.10	0.10	0.10
50	75	25	0.90	0.50	0.60	0.30	0.50	0.20	0.30	0.20	0.20	0.10	0.10	0.10	0.10	0.10

**KMC20T(Tr65x12)**

Input Speed (RPM)	Lifting Speed (MM/MIN)		F=20 Ton		F=16 Ton		F=12 Ton		F=10 Ton		F=7.5 Ton		F=5 Ton		F=2.5 Ton	
			H	L	H	L	H	L	H	L	H	L	H	L	H	L
	H	L	kW	kW	kW	kW	kW	kW	kW	kW	kW	kW	kW	kW	kW	kW
1500	2250	750	36.00	20.00	29.00	16.00	22.00	12.00	18.00	9.60	14.00	7.20	8.90	4.80	4.50	2.40
1000	1500	500	24.00	13.00	19.00	11.00	15.00	7.70	12.00	6.40	8.90	4.80	6.00	3.20	3.00	1.60
750	1125	375	18.00	9.60	15.00	7.70	11.00	5.80	8.90	4.80	6.70	3.60	4.50	2.40	2.20	1.20
500	750	250	12.00	6.40	9.50	5.10	7.10	3.80	6.00	3.20	4.50	2.40	3.00	1.60	1.50	0.80
300	450	150	7.10	3.80	5.70	3.10	4.30	2.30	3.60	1.90	2.70	1.40	1.80	1.00	0.90	0.50
200	300	100	4.80	2.60	3.80	2.10	2.90	1.50	2.40	1.30	1.80	1.00	1.20	0.60	0.60	0.30
100	150	50	2.40	1.30	1.90	1.00	1.40	0.80	1.20	0.60	0.90	0.50	0.60	0.30	0.30	0.20
50	75	25	1.20	0.60	1.00	0.50	0.70	0.40	0.60	0.30	0.40	0.20	0.30	0.20	0.10	0.10

**Performance Tables**

**KMC25T(Tr90x16)**

Input Speed (RPM)	Lifting Speed (MM/MIN)		F=25 Ton		F=20 Ton		F=16 Ton		F=12 Ton		F=10 Ton		F=7.5 Ton		F=5 Ton	
			H	L	H	L	H	L	H	L	H	L	H	L	H	L
	H	L	kW	kW	kW	kW	kW	kW	kW	kW	kW	kW	kW	kW	kW	kW
1500	2250	750	49.30	19.00	27.00	16.00	22.00	13.00	16.00	9.10	14.00	7.60	9.90	5.70	6.60	3.80
1000	1500	500	32.30	15.00	20.00	12.00	16.00	9.10	12.00	6.80	9.90	5.70	7.40	4.30	4.90	2.80
750	1125	375	24.60	9.50	14.00	7.60	11.00	6.10	7.90	4.50	6.60	3.80	4.90	2.80	3.30	1.90
500	750	250	16.40	7.60	11.00	6.10	8.40	4.80	6.30	3.60	5.30	3.00	3.90	2.30	2.60	1.50
300	450	150	9.90	5.70	7.90	4.50	6.30	3.60	4.70	2.70	3.90	2.30	3.00	1.70	2.00	1.10
200	300	100	6.60	3.80	5.30	3.00	4.20	2.40	3.20	1.80	2.60	1.50	2.00	1.10	1.30	0.80
100	150	50	3.30	1.90	2.60	1.50	2.10	1.20	1.60	0.90	1.30	0.80	1.00	0.60	0.70	0.40
50	75	25	1.60	0.90	1.30	0.80	1.10	0.60	0.80	0.50	0.70	0.40	0.50	0.30	0.30	0.20

**KMC35T(Tr100x20)**

Input Speed (RPM)	Lifting Speed (MM/MIN)		F=35 Ton		F=30 Ton		F=25 Ton		F=20 Ton		F=15 Ton		F=10 Ton		F=5 Ton	
			H	L	H	L	H	L	H	L	H	L	H	L	H	L
	H	L	kW	kW	kW	kW	kW	kW	kW	kW	kW	kW	kW	kW	kW	kW
1500	2813	938	72.00	27.00	42.00	23.00	35.00	19.00	28.00	16.00	21.00	12.00	14.00	7.60	6.90	3.80
1000	1875	625	48.50	20.00	32.00	17.00	26.00	15.00	21.00	12.00	16.00	8.50	11.00	5.70	5.20	2.80
750	1406	469	36.40	14.00	21.00	12.00	18.00	9.50	14.00	7.60	11.00	5.70	6.90	3.80	3.50	1.90
500	938	313	24.20	11.00	17.00	9.10	14.00	7.60	12.00	6.10	8.30	4.50	5.60	3.00	2.80	1.50
300	563	188	14.50	8.00	13.00	6.80	11.00	5.70	8.30	4.50	6.30	3.40	4.20	2.30	2.10	1.10
200	375	125	9.80	5.30	8.40	4.50	7.00	3.80	5.60	3.00	4.20	2.30	2.80	1.50	1.40	0.80
100	188	63	4.90	2.70	4.20	2.30	3.50	1.90	2.80	1.50	2.10	1.10	1.40	0.80	0.70	0.40
50	94	31	2.50	1.30	2.10	1.10	1.80	0.90	1.40	0.80	1.00	0.60	0.70	0.40	0.30	0.30



**Performance Tables**
**KMC50T(Tr120x20)**

Input Speed (RPM)	Lifting Speed (MM/MIN)		F=50 Ton		F=45 Ton		F=40 Ton		F=35 Ton		F=30 Ton		F=20 Ton		F=10 Ton	
			H	L	H	L	H	L	H	L	H	L	H	L	H	L
	H	L	kW	kW	kW	kW	kW	kW	kW	kW	kW	kW	kW	kW	kW	kW
1500	2813	938	133.00	70.00	80.00	42.00	71.10	37.00	62.20	33.10	53.30	28.40	35.50	18.90	17.70	9.40
1000	1875	625	88.70	35.50	60.00	31.00	53.30	28.40	46.50	24.80	39.90	21.30	26.70	14.20	13.40	7.10
750	1406	469	66.50	23.70	40.00	21.00	35.50	18.90	31.00	16.60	26.20	14.20	17.70	9.50	8.90	4.70
500	938	313	35.00	18.90	32.00	17.00	28.40	15.20	24.80	13.30	21.30	11.40	14.20	7.60	7.10	3.80
300	563	188	26.00	14.20	24.00	12.80	21.30	11.40	18.60	9.90	16.00	8.50	10.70	5.70	5.30	2.90
200	375	125	18.00	9.50	16.00	8.50	14.20	7.50	12.40	6.60	10.60	5.70	7.10	3.70	3.50	1.80
100	188	63	8.90	4.50	8.00	4.00	7.10	3.60	6.20	3.20	5.30	2.80	3.50	1.80	1.70	0.90
50	94	31	4.40	2.20	4.00	2.00	3.50	1.80	3.10	1.60	2.60	1.30	1.70	0.90	0.80	0.45

**KMC100T(Tr160x24)**

Input Speed (RPM)	Lifting Speed (MM/MIN)		F=100 Ton		F=90 Ton		F=80 Ton		F=70 Ton		F=60 Ton		F=40 Ton		F=20 Ton	
			H	L	H	L	H	L	H	L	H	L	H	L	H	L
	H	L	kW	kW	kW	kW	kW	kW	kW	kW	kW	kW	kW	kW	kW	kW
1500	2875	958	203.00	106.00	183.00	96.00	162.00	85.00	142.00	74.00	122.00	64.00	81.00	42.60	40.60	21.30
1000	1917	639	152.00	80.00	137.00	72.00	122.00	64.00	106.00	55.00	91.00	48.00	61.00	32.00	30.50	16.00
750	1438	479	102.00	53.00	91.00	48.00	81.00	42.00	71.00	37.00	61.00	32.00	41.00	21.00	21.00	10.50
500	958	319	81.40	42.50	73.00	38.00	65.00	34.00	56.00	29.00	48.00	25.50	32.00	17.00	16.00	8.50
300	575	192	61.00	32.00	55.00	28.80	49.00	25.00	42.00	22.00	36.00	19.20	24.00	12.70	12.00	6.30
200	383	128	40.60	21.00	36.00	19.20	32.50	17.00	28.00	15.00	24.00	12.80	16.00	8.50	8.00	4.20
100	192	64	20.30	10.60	18.30	9.60	16.00	8.50	14.00	7.50	12.00	6.40	8.00	4.30	4.00	2.10
50	96	32	10.20	5.30	9.10	4.80	8.00	4.20	7.00	3.80	6.00	3.20	4.00	2.10	2.00	1.05

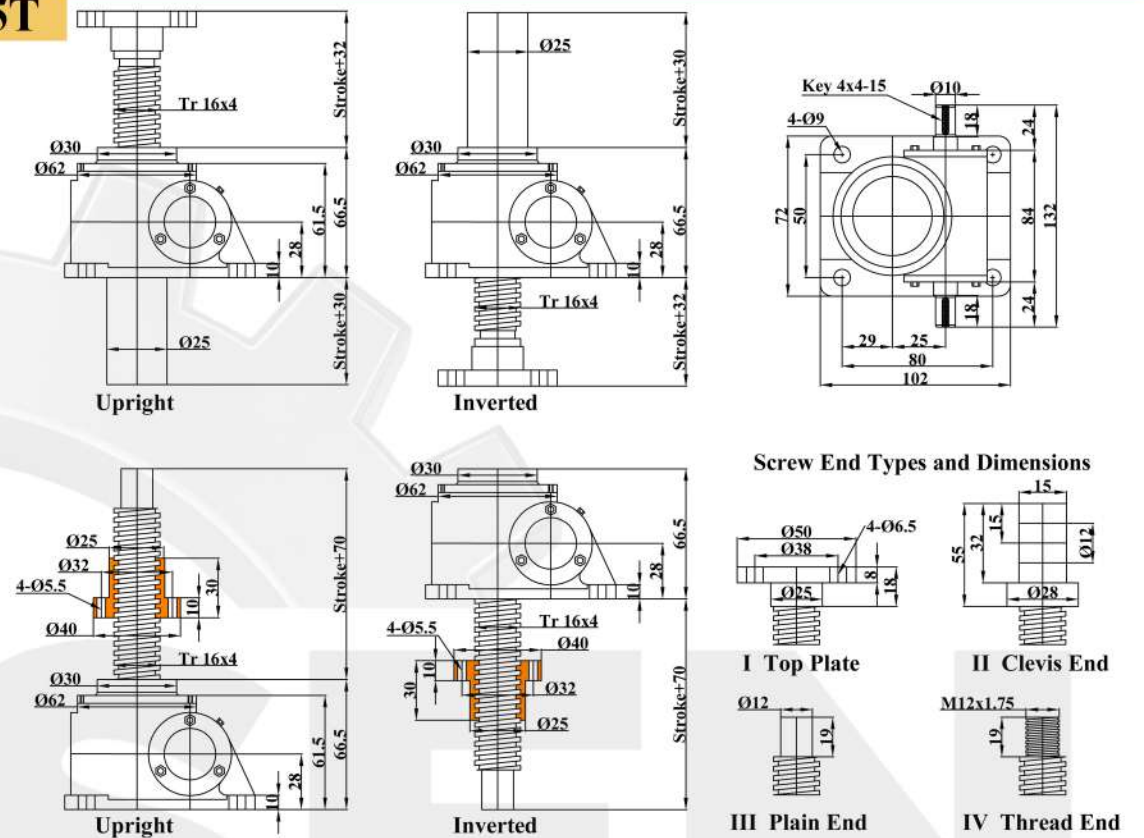
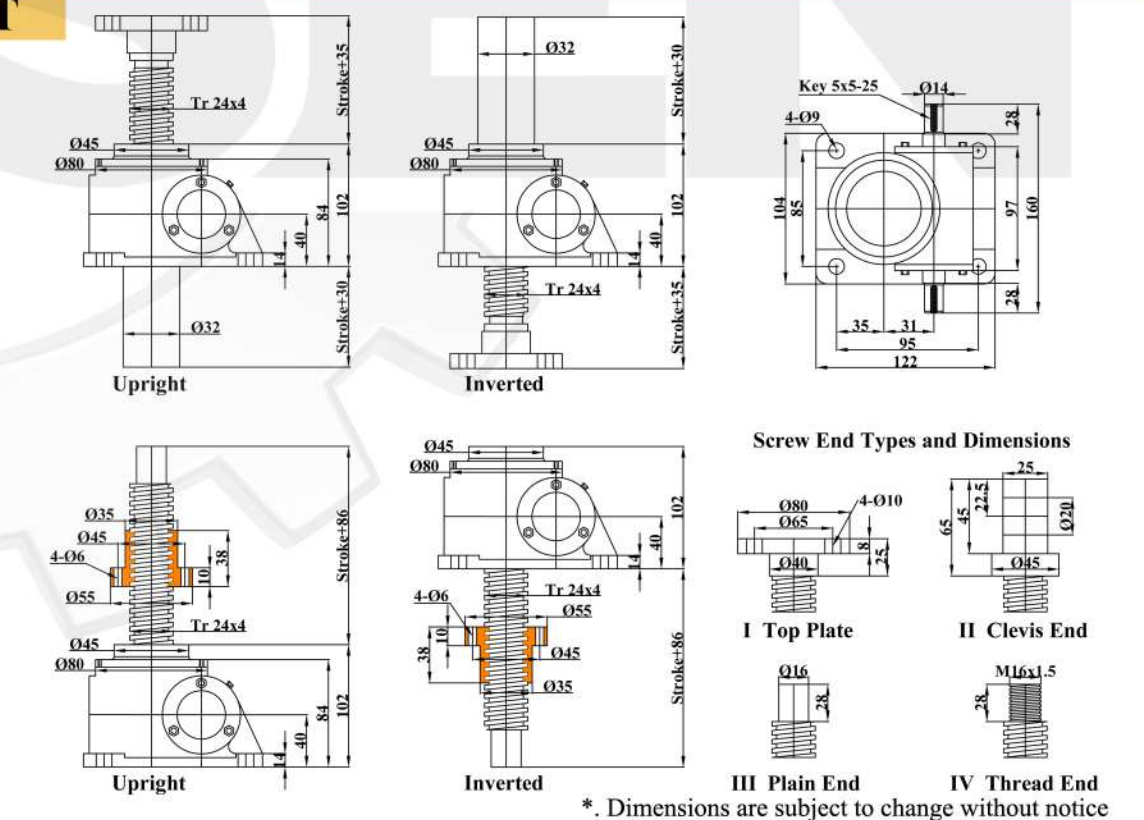
**Overall Dimensions**
**KMC0.5T**

**KMC1T**

\*. Dimensions are subject to change without notice

## Overall Dimensions

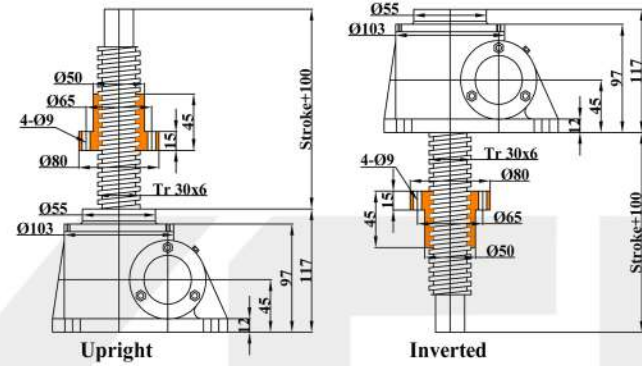
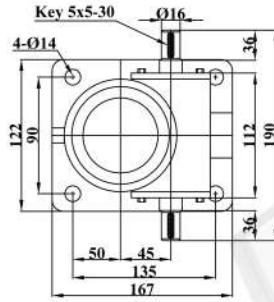
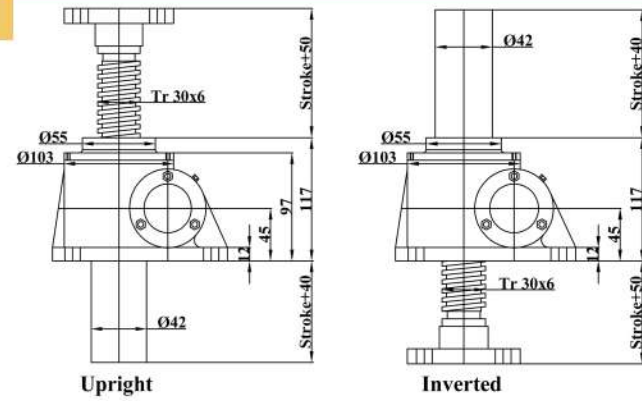
### KMC2.5T



#### Screw End Types and Dimensions

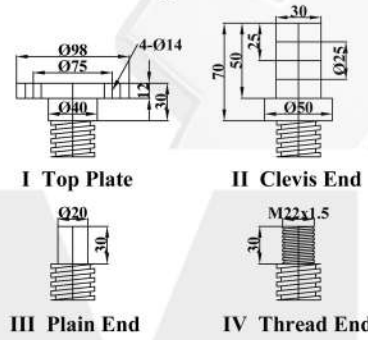

## Overall Dimensions

### KMC10T KMC15T

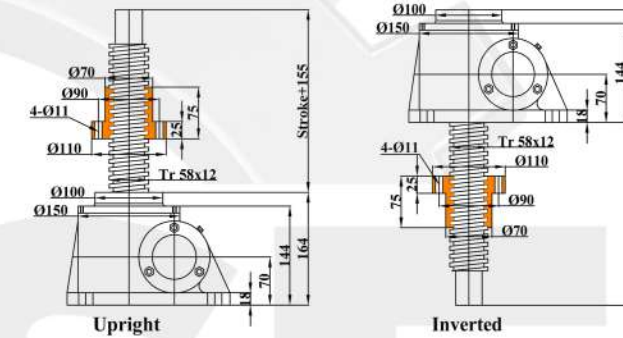
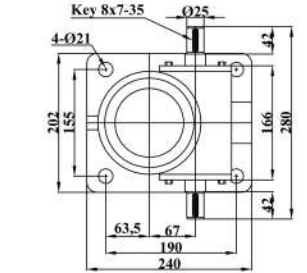
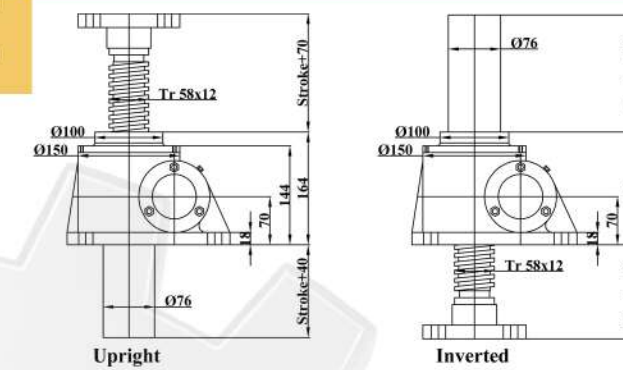

#### Screw End Types and Dimensions

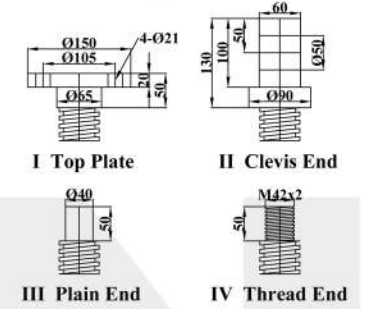

### KMC5T

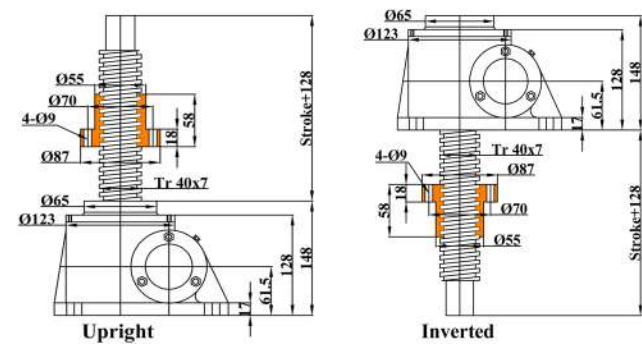
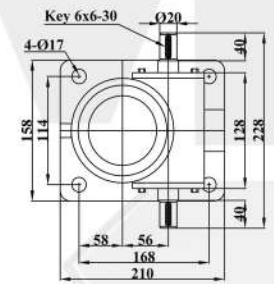
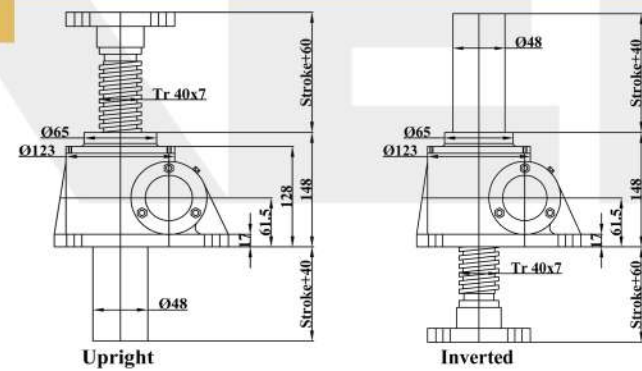

#### Screw End Types and Dimensions

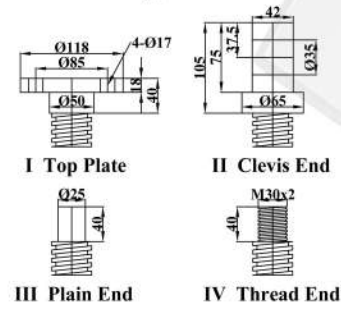

### KMC20T

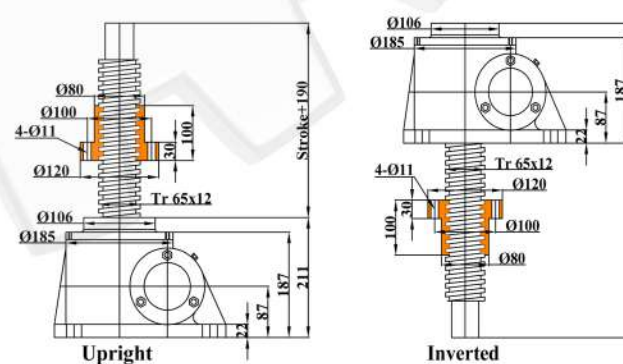
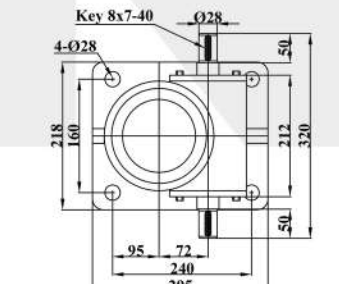
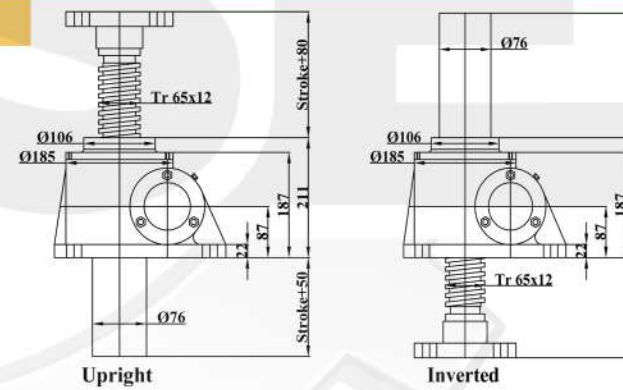

#### Screw End Types and Dimensions

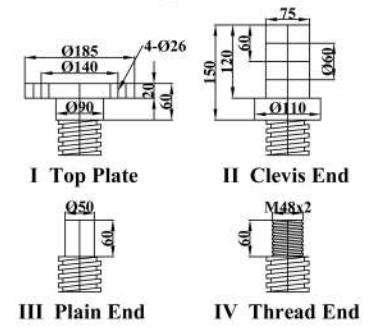

\*. Dimensions are subject to change without notice

\*. Dimensions are subject to change without notice

## Overall Dimensions

### KMC25T

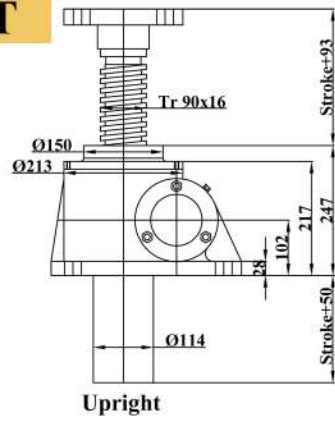

Upright

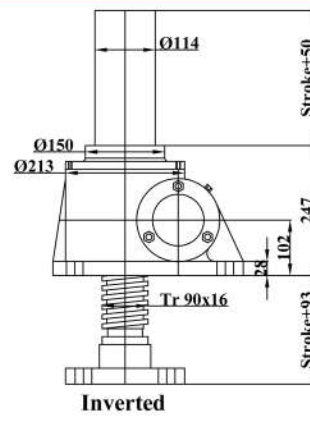

Inverted

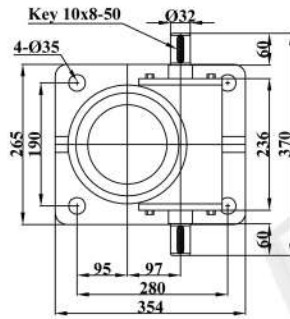

Screw End Types and Dimensions

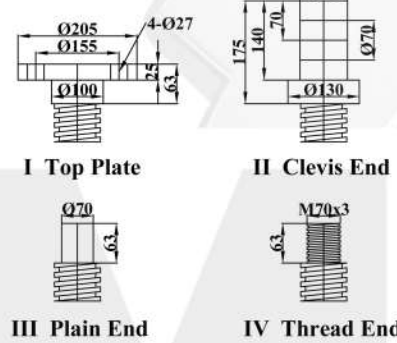

I Top Plate

II Clevis End

III Plain End

IV Thread End

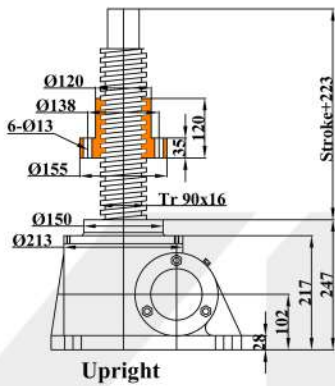

Upright

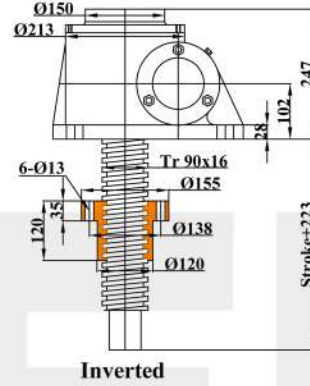

Inverted

### KMC35T

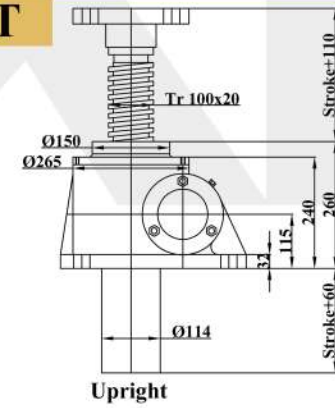

Upright

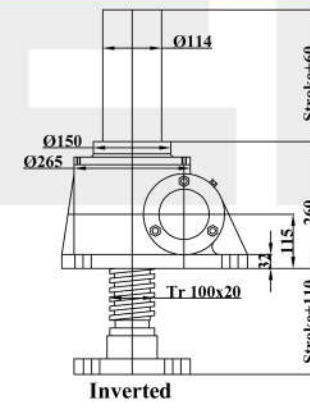

Inverted

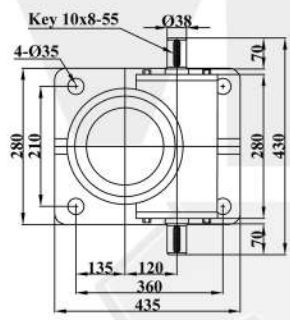

Screw End Types and Dimensions

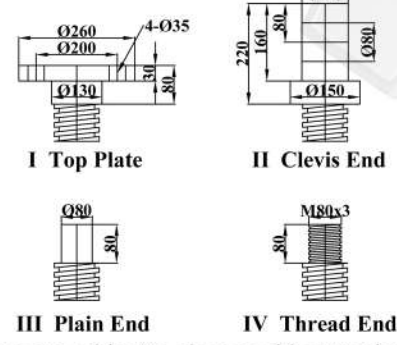

I Top Plate

II Clevis End

III Plain End

IV Thread End

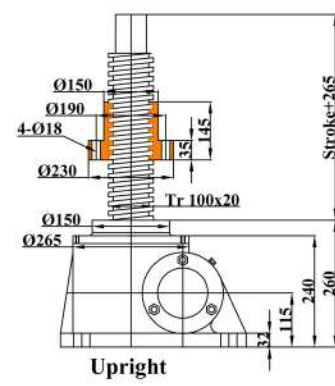

Upright

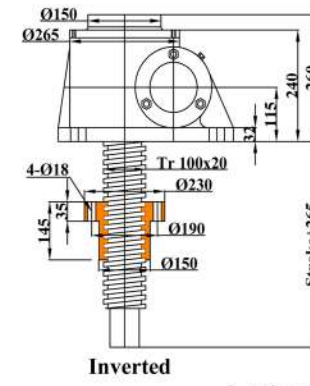

Inverted

### KMC50T

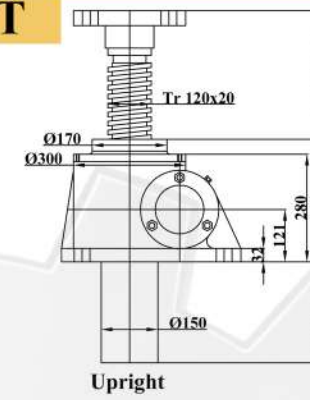

Upright

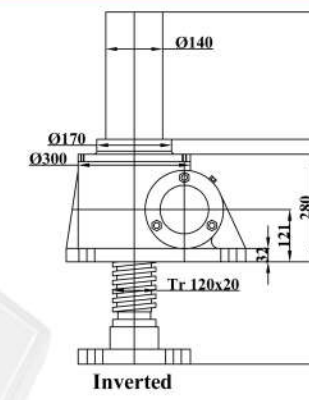

Inverted

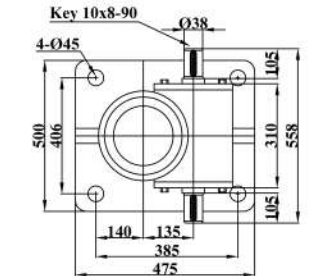

Screw End Types and Dimensions

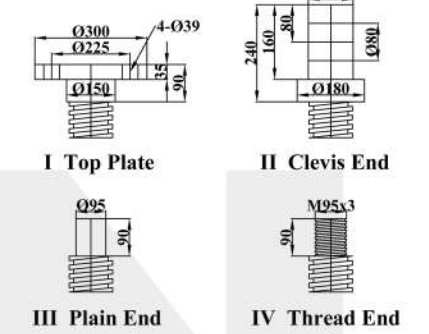

I Top Plate

II Clevis End

III Plain End

IV Thread End

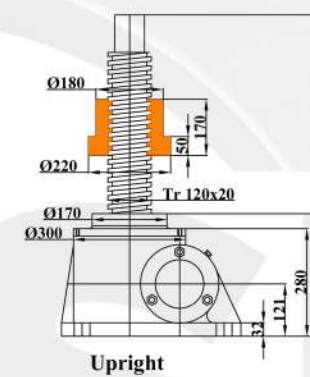

Upright

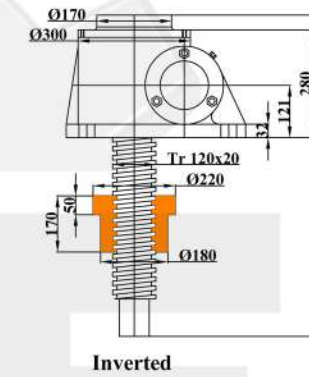

Inverted

### KMC100T

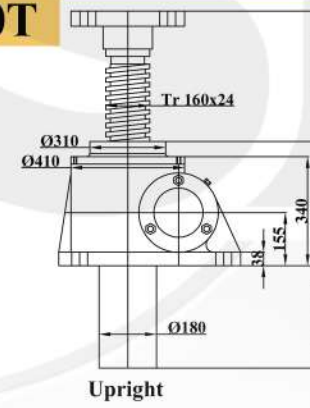

Upright

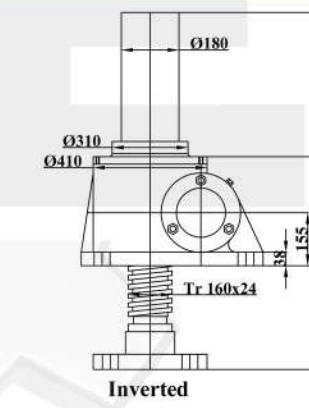

Inverted

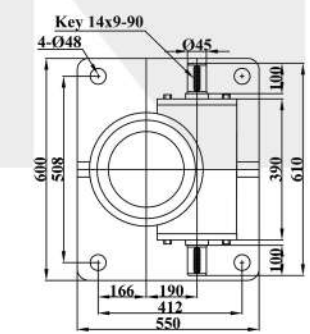

Screw End Types and Dimensions

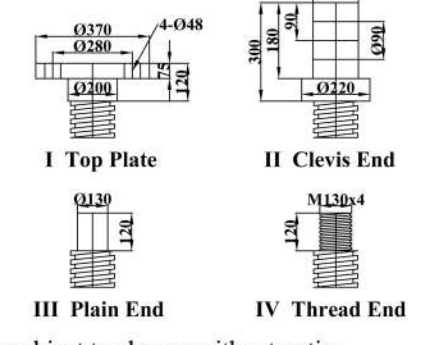

I Top Plate

II Clevis End

III Plain End

IV Thread End

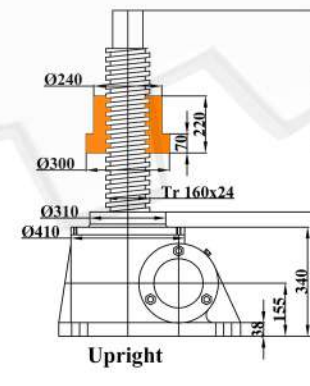

Upright

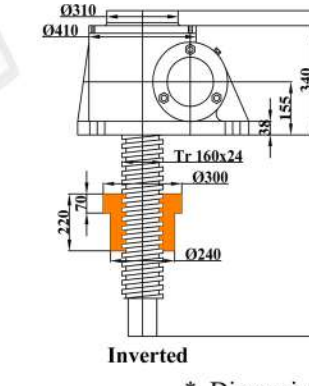

Inverted

\*. Dimensions are subject to change without notice

\*. Dimensions are subject to change without notice

**Permitted Lateral Force On the Lifting Screw Fs (N)**

Lateral forces are to be prevented by constructive measures. The Lateral forces on lifting Screws or travelling nuts exercise a reinforced edge compression on the movement thread, leading to increased wear and a shortened service life.

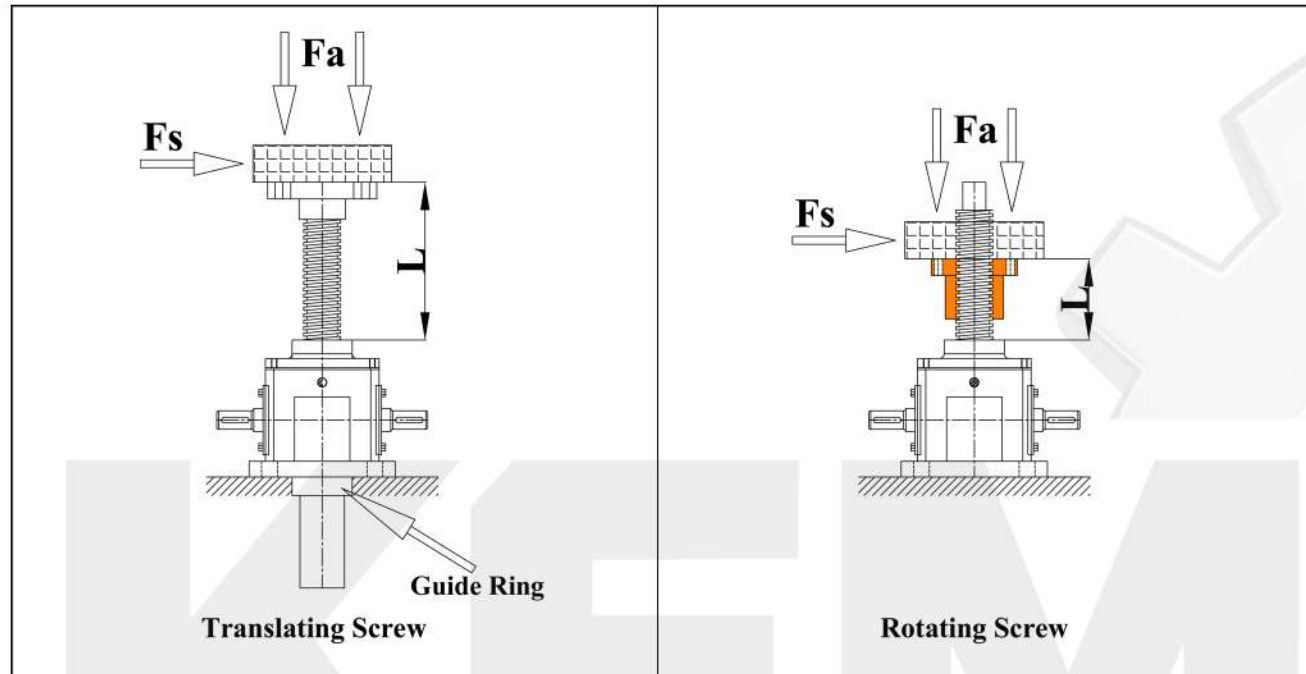

The permitted lateral force ( $F_s$ ) on the lifting screw depends on the axial force ( $F_a$ ), the diameter of the screw ( $d$ ) and the length of the lifting screw  $L$ . As compression and buckling force exercise negative influence, these factors were taken into account when determining this permitted lateral force ( $F_s$ ). The maximum length of the lifting screw ( $L$ ) is limited by the value generally used in mechanical engineering applications: "unguided lifting screw length = 4x free clamping length".

- **Note:** Lateral force on the lifting screw is only permitted on screw jacks fitted with **two guide rings**.
- **Note:** For rotating screw jack, The permitted lateral force ( $F_s$ ) is in static configuration only.

**Permitted Lateral Force On the Lifting Screw Fs (N)**

For compressive load applications, please use the following diagrams to determine the maximum permitted lateral force.

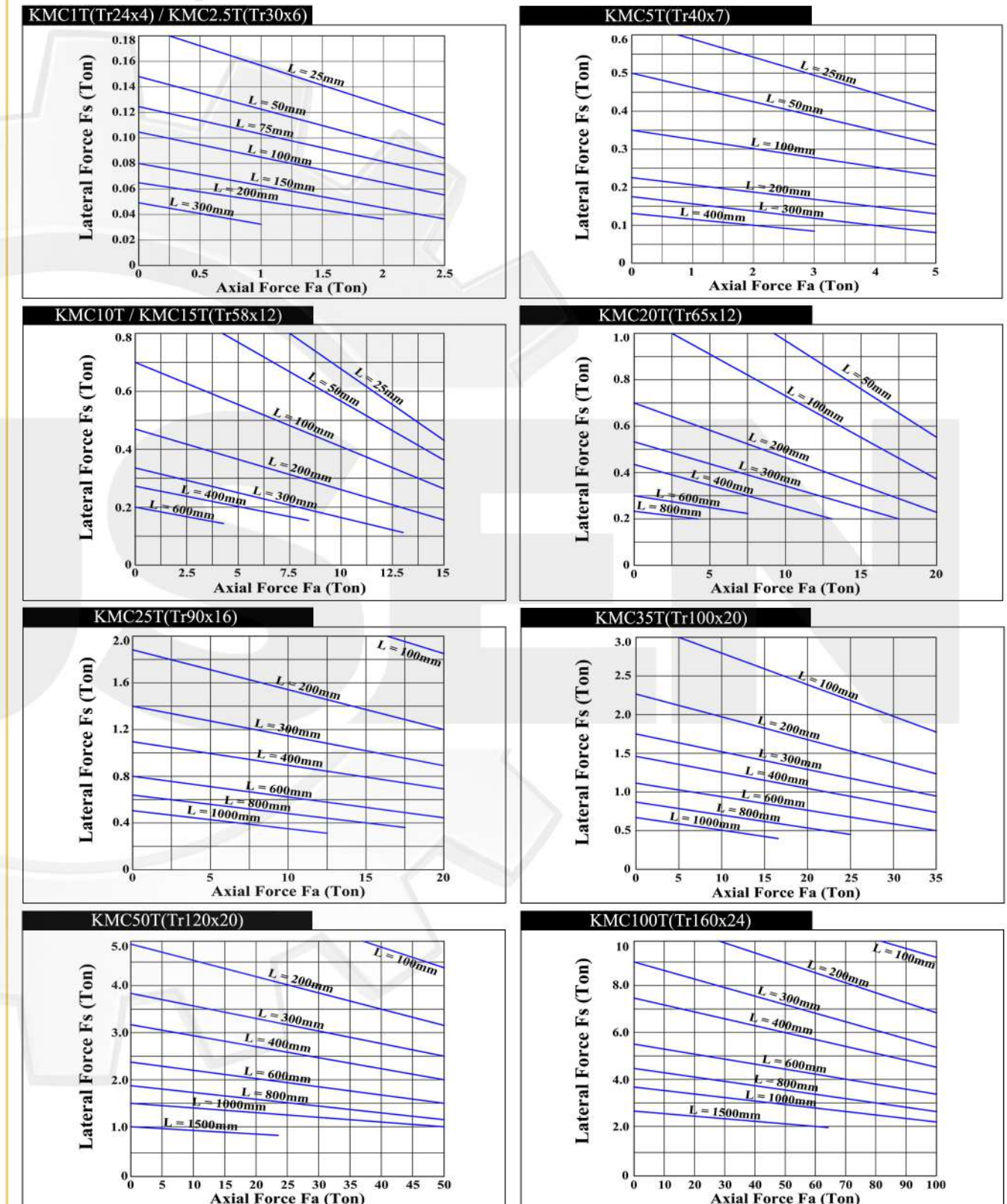

**Permitted Radial Force On Input Shaft Fr (N)**

Toothed and/or chain wheels along with pulley wheels bring radial forces to bear on the drive shaft of the worm gear screw jacks. The maximum permitted value depends on the lifting force and size of the jacking element.

The table is calculated for  $\alpha \sim 30^\circ$  or  $330^\circ$ . This is the least-favorable bearing with respect to application of the lifting force and turning direction.

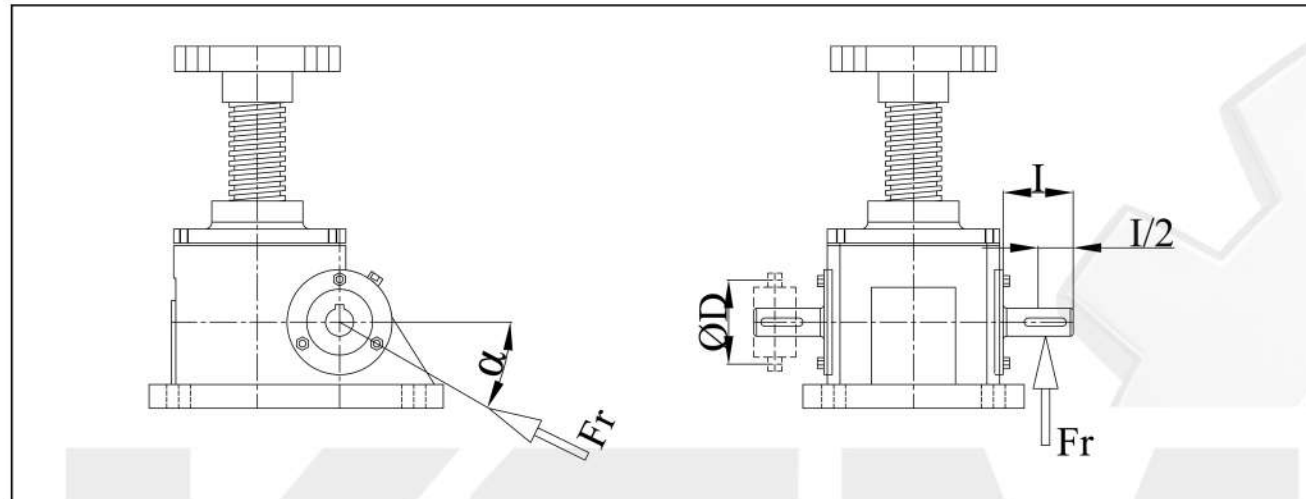

- Permitted radial force ( $Fr$ ) on application of force in  $I/2$

- Minimum diameter ( $D$ ) for toothed wheel or pulleys:

$$D_{min} = (19100 \times P) / (Fr \times n) = 2 \times T / Fr$$

$P$ = Power rating (kW)    $Fr$ = Max. Radial force (N)    $n$ = Input speed (rpm)    $T$ = input torque (Nm)

Model	Fr max (N)	T max (Nm)
KMC0.5T	250	1.9
KMC1T	350	5.7
KMC2.5T	350	18
KMC5T	750	44.2
KMC10T/15T	1000	108
KMC20T	1300	182
KMC25T	2000	314
KMC35T	2300	398
KMC50T	2400	796
KMC100T	5100	1415